



TNT 35 und TNT 35/7-24V

Test monitoring units

Connecting and Operating Instructions



Notes on Connecting and Operating Instructions

This connecting and operating instructions manual contains information on the proper use of test monitoring units TNT 35 and TNT 35/7-24V in accordance with its intended purpose.



All the information contained herein, in particular the safety notes, need to be carefully observed.

Notes regarding safety and warnings are marked by this symbol  .

Notes regarding important pieces of information are marked by the symbol  .

This connecting and operating instructions manual must be stored carefully. It must be available for the entire operating time of the test monitoring units TNT 35 and TNT 35/7-24V.

The Leuze lumiflex GmbH + Co. KG is not liable for damages caused by improper use. Acquaintance with these instructions is an element of the knowledge required for proper use.

© Reprints and reproduction, in whole or in part, are permitted only with the explicit permission of

Leuze lumiflex GmbH + Co. KG
Liebigstraße 4
D-82256 Fürstenfeldbruck, Germany
Tel. +49 (0) 81 41/53 50-0
Fax +49 (0) 81 41/53 50-190
E-Mail: lumiflex@leuze.de
<http://www.leuze.de>

Contents

1	General Information	5
1.1	Certifications	5
1.2	General Information	5
1.3	Definition of Terms	5
1.4	Selection of Optical Electronic Protective Devices	6
2	Safety Notices	7
2.1	Safety Standard	7
2.2	Intended Use	7
2.2.1	Application requirements	7
2.2.2	Areas of application	8
2.3	Organizing Measures	8
3	Mounting of the Safety System	9
3.1	Mounting of the Protective Photoelectric Sensor	9
3.1.1	Multi-axle installation	10
4	Function and Commissioning of the TNT 35	12
4.1	Function characteristics of the safety system	12
4.1.1	Display and Operating Instruments	12
4.2	Electrical Installation	13
4.2.1	Supply wiring	14
4.2.2	Start input wiring	15
4.2.3	Wiring of single-beam protective photoelectric sensors	17
4.2.4	Wiring of single-beam protective photoelectric sensors in series	18
4.2.5	Wiring safety output	19
4.2.6	Wiring of the message outputs	22
4.2.7	Setting of the operating mode	23
4.3	Operating states without start- and restart-disable.	25
4.4	Operating states with start- and restart-disable without relay monitoring (EDM)	28
4.5	Operating states with start- and restart-disable and with relay monitoring (EDM)	32
4.6	Fault indication and device reset	35
4.7	Technical Data	36
5	Function and Commissioning of the TNT 35/7-24V	38
5.1	Function characteristics of the safety system	38
5.1.1	Display and Operating Instruments	39
5.2	Electrical Installation	39
5.2.1	Supply wiring	40
5.2.2	Sensor voltage supply	40
5.2.3	Start input wiring	41
5.2.4	Wiring of single-beam protective photoelectric sensors	43
5.2.5	Wiring of single-beam protective photoelectric sensors in series	44
5.2.6	Wiring safety output	45
5.2.7	Wiring of the message outputs	47
5.2.8	Setting of the operating mode	48
5.3	Operating states without start- and restart-disable.	50
5.4	Operating states with start- and restart-disable without relay monitoring (EDM)	53
5.5	Operating states with start- and restart-disable and with relay monitoring (EDM)	57
5.6	Fault indication and device reset	60
5.7	Technical Data	62

6	Applications	64
6.1	Example with retro-reflective photoelectric safety sensor SRK 96	64
6.2	Example with a protective photoelectric sensor SLS 96	66
6.3	Example with a protective light barrier ECO	67
6.4	Example with a protective photoelectric barrier ROBUST	68
6.5	Example of a TNT 35 with protective photoelectric sensor SLS 96 and EMERGENCY SHUT-DOWN function	69
6.6	Example of a TNT 35/7-24V with a retro-reflective photoelectric safety sensor SRK 96 ...	70
6.7	Example of a TNT 35/7-24V with two retro-reflective photoelectric safety sensors SRK 96	71
7	Appendix	72
7.1	Remaining Risks (EN 292-1)	72
8	EC Declaration of Conformity	73

1 General Information

1.1 Certifications

The TNT 35 and TNT 35/7-24V monitoring units have been developed and manufactured in accordance with the applicable European standards and directives.

The manufacturer of the product, Leuze lumiflex GmbH + Co. KG in D-82256 Fürstenfeldbruck, possesses a certified quality assurance system in accordance with ISO 9001.



1.2 General Information



There are two device variations described in this connecting and operating instructions. The difference between the two devices is in their supply voltage. The TNT 35 is intended for 24V DC operation. The TNT 35/7-24V is intended for 24V AC operation. The basic remarks concerning the functioning and assembly of the safety system are valid for both device variations.

An active optoelectronic protective device is part of the electrical equipment which has to be applied to those machines which contain the potential risk of bodily injury. They provide protection by causing the machine to move into a safe operating state before a person can get into a dangerous situation (EN 61496-1).

1.3 Definition of Terms

AOPD type 2

The EN 61496 describes two types of active optical electronic protective devices (AOPD) with respect to the requirements concerning safety relevant parts of control units (EN 954-1).

The AOPD type 2 fulfills the requirements of category 2 acc. to EN 954-1. A periodic function test has to detect malfunctions in the safety function. In case of a failure, the next machine cycle may not be released. A malfunction of the AOPD type 2 between the testings can cause the loss of the safety function. In normal function, at least one output switching element of the AOPD type 2 has to move into the OFF-position if the sensor reacts or if the power supply of the AOPD is interrupted.

Contactless active protective device (BWS)

Corresponds to AOPD

Output switching element (OSSD)

The part of the AOPD which is connected to the machine control and which moves into the OFF-position as soon as the sensor part reacts during normal operation.

Start disable

An equipment which disables the automatic machine start if the power supply of the contactless active protective device is switched on or if it had been interrupted and switched on again.

Start testing

A manual or automatic test which is performed after the contactless active protective device has been switched on. It tests the complete safety-relevant control system before the normal machine operation is induced.

Muting

The intentional bridging of the safety function, e.g. during material transport into the hazardous area.

Muting sensors

Muting sensors define between persons and transported material. If the muting sensors are activated simultaneously or in the intended order, the safety function of the AOPD is bridged. Material can be brought into the hazardous area without taking the machine out of operation.

Relay monitoring

The relay monitoring checks before every release of the switching outputs if the succeeding contactors are open. Only then, a new release is possible.

Restart-disable

A function which prevents an automatic restart of a machine after

- sensor detection during a potentially dangerous motion of the machine,
- a change in the operating mode of the machine and
- a change in the actuation mode of the machine.

1.4 Selection of Optical Electronic Protective Devices

The following strategy is to be applied (iterative process):

1. Determination of the protected area
2. Determination of the protective function
 - Finger or hand protection
 - Access protection for persons
 - Presence detection
3. Determination of the control category
4. Calculation of the safety distance

Determination of the protected area

Through risk calculation, the following has to be observed:

- the size of the safety field
- the access points
- the hazardous areas
- bypassing possibilities

Determination of the protective function:

Finger and hand protection: The user is close to the hazardous area.

Access protection: Access to the hazardous area is protected.

Presence detection: A hazardous area which is completely surrounded by permanently installed protective devices is monitored for presence of objects or access protection and presence detection are combined.

2 Safety Notices

2.1 Safety Standard

The test monitoring units TNT 35 and TNT 35/7-24V were developed and manufactured in accordance with current European standards and directives. All units satisfy the safety technology requirements of category 2 according to EN 954-1 and EN 61496-1.

2.2 Intended Use

The safety switching units TNT 35 and TNT 35/7-24V are used for the protection of hazardous areas or locations in combination with one or several protective photoelectric sensors or safety light barriers.



The protection of personnel and the device cannot be guaranteed if the device is operated in a manner not corresponding to its intended use.

2.2.1 Application requirements

Control of the machine or unit to be protected has to be controllable electrically. A switching signal generated by a TNT 35 or TNT 35/7-24V has to be followed by an immediate shut-down of the dangerous movement. For application and installation of the protective photoelectric sensors or light barriers, the current European guidelines and standards and/or the safety regulations of the employers' liability insurance association have to be observed.



Access to or changes of the device, except where expressly described in this operating manual, is not authorised.

2.2.2 Areas of application

The test monitoring units TNT 35 and TNT 35/7-24V may be used as disconnecting protective devices for the protection of hazardous areas on power-driven machines.

They are authorised for the following areas of application (extract):

- Edge, frame, star, and carcass presses in lumber industry acc. to prEN 691 resp. ZH 1/3.19
- Printing and paper processing machines acc. to prEN 1010
- Power driven windows, doors, and gates acc. to ZH 1/494
- Storage equipment and devices acc. to ZH 1/482 and DIN 15185 part 2
- Textile machines acc. to VBG and DIN EN ISO 11 111
- Food processing equipment acc. to prEN 1672-1 resp. VBG 77
- Packaging machinery acc. to prEN 415-1 to -7 resp. VBG 76
- Meat processing equipment acc. to prEN 12463 resp. VBG 79
- Machines of the chemical, rubber, and plastic industry acc. to VBG 22

2.3 Organizing Measures

All entries in this operating manual must be heeded, in particular those in the chapters "Safety Notices" and "Commissioning".

Carefully store this operating manual where it is accessible at all times.

Observe the locally applicable legal regulations and the rules of the employers' liability insurance association.

Mounting, commissioning and maintenance of the device must only be carried out by qualified personnel. Electrical work must be carried out by a certified electrician.

Adjustment and change of the safety field for the protection of persons may only be carried out by an authorised person.

Repairs, in particular the opening of the housing, may only be carried out by the manufacturer or a person authorised by the manufacturer.

3 Mounting of the Safety System



The mounting instructions in this chapter have to be heeded for fault-free functioning of the whole safety system.

3.1 Mounting of the Protective Photoelectric Sensor

It is absolutely mandatory that the valid guidelines and standards are observed when mounting the protective photoelectric sensors.

Safety distance

A certain time delay applies between the interruption of the light beam of the protective photoelectric sensors and the stand-still of the machine. The photoelectric sensors have to be installed in such a way that the dangerous area cannot be reached within this time delay. The minimum distance for safeguarding the hazardous area is 850 mm.

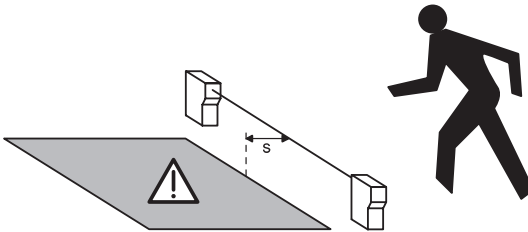

Fig. 3.1-1: Safety distance S between photoelectric sensor and hazardous area

Calculation of the safety distance

The safety distance S between photoelectric sensor and hazardous area is calculated acc. to EN 999 using the following formula:

$$S = K * T + C$$

S = Safety distance between photoelectric sensor and hazardous area

K = Grip and approach speed

T = Time delay between interruption of the light beam and stand-still of the machine

C = Safety constant

1200 mm for single-axle arrangement,

850 mm for multi-axle arrangement

Example for the calculation of the safety distance:

A machine with a system response time of 100 ms has to be equipped with a two-beam safeguarding. The response time of the two-beam AOPD and the test monitoring unit TNT 35 is 20 ms.

Application of the formula: $S = K * T + C$

Where:

- S = the minimum distance of the two-beam AOPD from the hazardous area
- K = approach speed 1600 mm/s (EN 999)
- T = sum of the system response time of the machine and response time of the AOPD
850 mm with multi-axe installation

This results in:

$$S = (1600 \text{ mm/s} * (100 \text{ ms} + 20 \text{ ms})) + 850 \text{ mm}$$

$$S = 1042 \text{ mm}$$

3.1.1 Multi-axe installation

For the safeguarding of hazardous areas, the level of desired protection and the number of light beams are determined in EN 999 or through a risk analysis acc. to EN 954-1.

With multi-axe installation, parallel light beams always have to run in opposite directions. Otherwise the light beams can cause mutual interference and disturb proper functioning.

Depending on the number of photoelectric sensor pairs, the single systems have to be mounted at different heights acc. to EN 999. The number of needed systems results from the corresponding type C standard or risk evaluation.

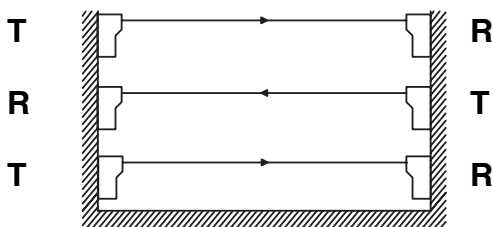

Fig. 3.1-2: Multi-axe installation

Deflection mirrors

A number of important factors have to be observed when using deflection mirrors:

- With any light beam deflection, a loss of operating range occurs. Per deflection mirror, the loss is approx. 15 %.
- Contamination of the deflection mirrors should be avoided.
- Environmental conditions such as steams and dust-containing air heavily limit the operating range.
- When installing deflection mirrors, the optical axis of the photoelectric sensor must be centered to the mirror.

- A laser alignment aid made by Leuze, e.g. ARH 2 facilitates alignment over large distances.

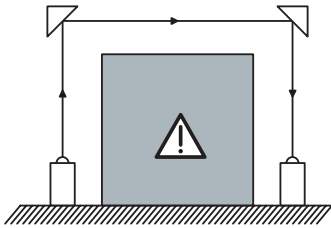

Fig. 3.1-3: Arrangement of the deflection mirrors

Reflection bypass

Surfaces located parallel to the light beam can cause a reflection bypass. An object within the light path is then no longer detected.

The photoelectric sensor has to be mounted with a minimum lateral distance to the reflecting surface. This distance results from the opening angle ($\pm 4^\circ$) and the distance between transmitter and receiver.

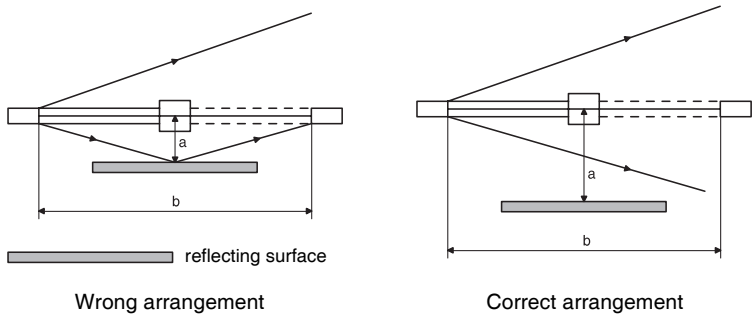

Fig. 3.1-4: Reflection bypass

Minimum distance to the reflecting surface						
Between transmitter and receiver (b)	2 m	3 m	4 m	5 m	6 m	10 m
To light beam (a) approx.	0.20 m	0.30 m	0.40 m	0.50 m	0.60 m	1.0 m

4 Function and Commissioning of the TNT 35

4.1 Function characteristics of the safety system

The complete safety system consists of a TNT 35 and accompanying protective photoelectric sensors or light barriers.

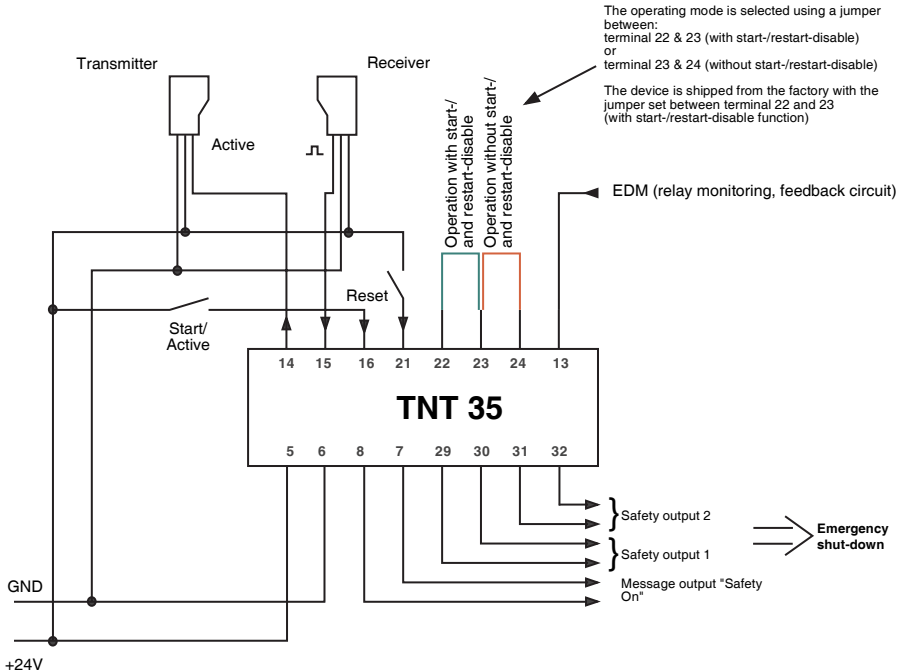

Fig. 4.1-1: Installation of the complete safety system

After the TNT 35 is switched on via the start input, the functionality of the protective photoelectric sensors is monitored in two-second cycles.

The electrical integration into the controller has to be performed acc. to the corresponding safety category acc. to EN 954-1. The voltage free safety relay outputs can be directly used for shut-down of the dangerous movement.

Inside the monitoring unit TNT 35, a selectable start- and restart-disable, as well as a selectable relay monitoring input are integrated.

4.1.1 Display and Operating Instruments

The test monitoring unit TNT 35 features integrated LEDs to indicate the state of the system.

The start- and restart-disable, as well as the relay monitoring functions are set on the TNT 35 using the corresponding jumpers on the connection terminals.

Overview - Display Elements

- LED "Sensor"
Status of the safety field state
- LED "Start/Active"
Status of the start and activation input
- LED "EDM"
Status of the relay monitoring
- LED "OFF/ON"
Status of the safety circuit (open or closed)

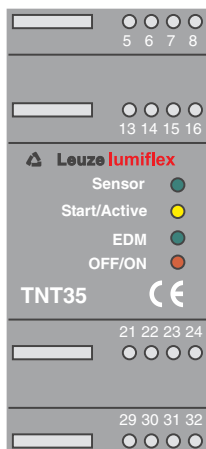

Fig. 4.1-2: Display elements TNT 35

4.2 Electrical Installation



The electrical installation is only to be performed by specialised personnel. Supply and signal lines have to be installed separately from power lines during installation.

Inside the switching cabinet, suitable spark extinction has to be provided if using contactors.

When installing drive motors and brakes, the corresponding installation manuals have to be observed.

The power supply for the TNT 35 must be equipped with a protective mains separation device according to IEC 60742. The power supply unit used to operate the TNT 35 has to be able to compensate for changes and interruptions of the supply voltage acc. to EN 61496-1.

4.2.1 Supply wiring

The test monitoring unit TNT 35 is supplied with 24V DC +/- 15%. The max. current consumption is 200mA.

The +24V supply voltage is connected to terminal 5 and the GND is connected to terminal 6.

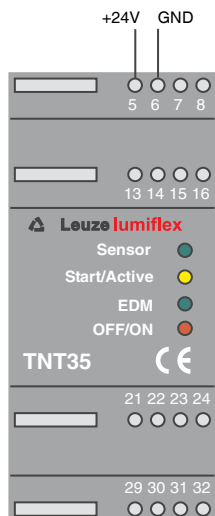

Fig. 4.2-1: Supply wiring

4.2.2 Start input wiring

The Start input (terminal 16) works both in the operating mode "with start- and restart-disable" and "without start- and restart-disable" in different ways:

- In the operating mode with start- and restart-disable, the TNT 35 expects two signal changes (push-button function) as switch-on signal. A failure in the start-/restart button, e.g. due to contact malfunction is safely detected by the TNT 35.

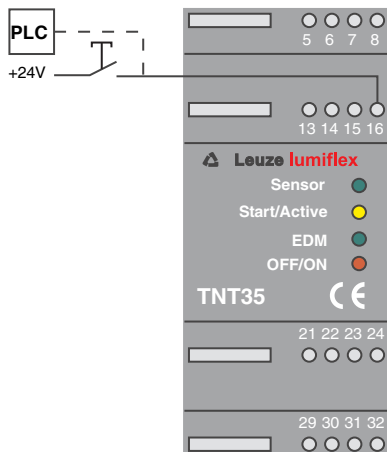

Fig. 4.2-2: Wiring of the start input "with start- and restart-disable"

- In the operating mode without start- and restart-disable, the start input works as activation input. As soon as a HIGH active signal is present at the start input (terminal 16) and the safety field is free, the safety outputs are closed.

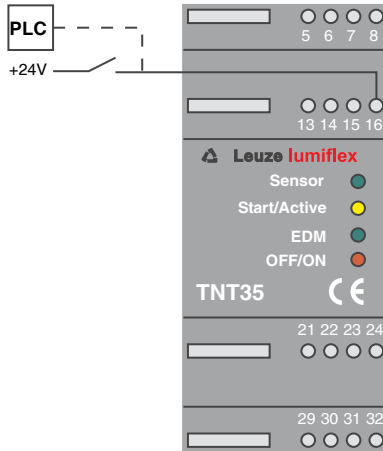

Fig. 4.2-3: Wiring of the start input "without start- and restart-disable"

4.2.3 Wiring of single-beam protective photoelectric sensors

The activation input of the protective photoelectric sensor can be directly connected to terminal 14 on the TNT 35. The switching output of the receiver can be directly connected to terminal 15.

The GND potential present on terminal 6 serves as a reference potential for both signals. The supply of the protective photoelectric sensors comes directly from the 24V power supply unit.

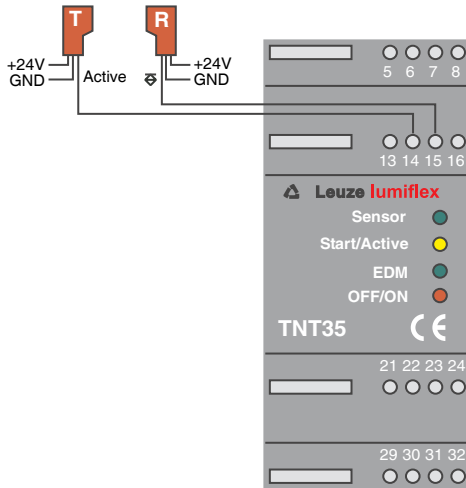

Fig. 4.2-4: Wiring of single-beam protective photoelectric sensors

4.2.4 Wiring of single-beam protective photoelectric sensors in series

Several photoelectric sensor pairs can be connected in series with multi-axle arrangements on a machine or system. The adjacent picture shows a three-axle photoelectric sensor arrangement. It is possible to operate up to six photoelectric sensor pairs on one TNT 35.

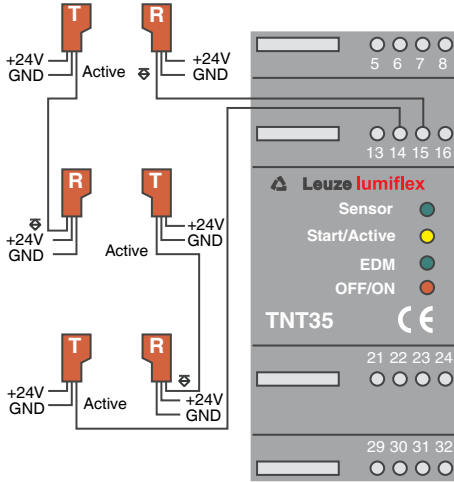

Fig. 4.2-5: Wiring of single-beam protective photoelectric sensors in series

Function characteristics:

The TNT 35 (terminal 14) activates the first photoelectric sensor transmitter. The receiver is activated via the first optical path and, by using its output, activates the second photoelectric sensor transmitter. The supply has to be provided on each photoelectric transmitter and receiver. The feedback to the TNT 35 (terminal 15) is done by the last photoelectric sensor receiver within the series connection.

Any time the light axis is interrupted, a message is issued to the TNT 35 through the series connection.

The series connection tests every transmitter and receiver for function capability while performing the testing procedure.

4.2.5 Wiring safety output

Integration in a one-channel release circuit without relay monitoring

Two safety relay outputs are connected in series. The release circuit can be connected to further components which are then wired to a common EMERGENCY SHUT-DOWN device.

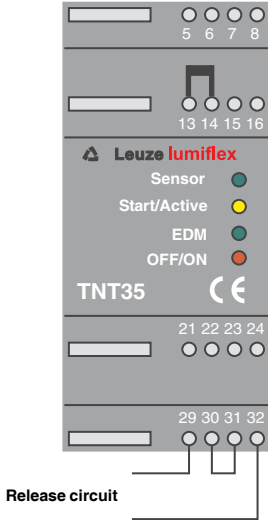

Fig. 4.2-6: Wiring safety output (one-channel release circuit)



For the operating mode without relay monitoring, the jumper that short-circuits terminals 13 and 14 must be set.

Integration in a two-channel release circuit without relay monitoring

Both safety relay outputs are integrated separately into the release circuits. These circuits can be connected with additional components which trigger a common EMERGENCY SHUT-DOWN device.

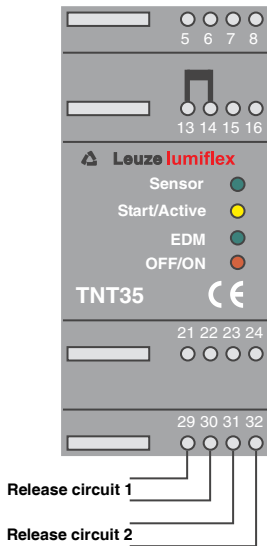

Fig. 4.2-7: Wiring safety output (two-channel release circuit)



For the operating mode without relay monitoring, the jumper that short-circuits terminals 13 and 14 **must** be set.

Integration with relay monitoring as EMERGENCY SHUT-DOWN device

The motor contactors for dangerous movement are connected to both safety relay outputs. For this purpose, forced contactors have to be used. In the connection diagram, no fuses are included. However, for correct function fuses are absolutely required. The maximum contact load of the safety relay outputs is 4A with 24VDC.

Control of the motor contactors happens via K1 and K2. If a contact of K1 and K2 should weld, a message is issued to the TNT 35 through the feedback circuit (EDM). A new start of the unit is possible only after removal of the failure in the output circuit.

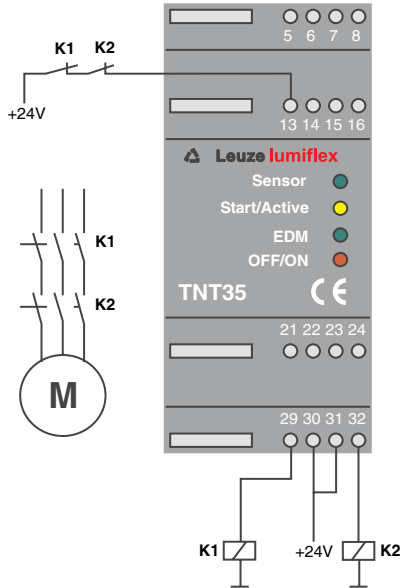

Fig. 4.2-8: Wiring of the safety output with relay monitoring

4.2.6 Wiring of the message outputs

Two message outputs are integrated in the TNT 35. Both are HIGH active, positive switching semiconductor outputs and can be either directly connected to a PLC or control a status display of a machine.

The message output "Safety on" is always active if the safety relay outputs are closed.

The message output "Error" is always active if the TNT 35 detects an error. Those errors can be internal or external.

Through linking of the status outputs in the controller, the following system states can be detected:

1. "Safety on" active, "Error" inactive
Normal operation of the TNT 35, no error detected
2. "Safety on" inactive, "Error" active
The TNT 35 detected a safety relevant failure which led to the switching off of the safety outputs.

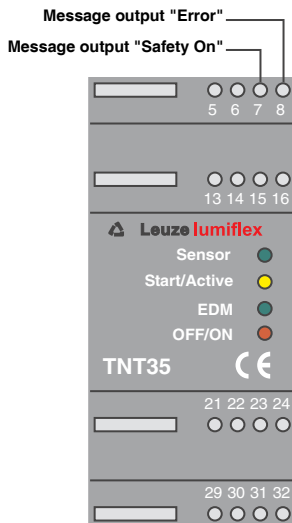

Fig. 4.2-9: Wiring of the message outputs

4.2.7 Setting of the operating mode

The start- and restart-disable function is selected on the device by setting a jumper between terminals 22 and 23 or terminals 23 and 24.



Terminals 22, 23 and 24 may only be used to for selecting the operating mode using the included short circuit jumpers.

With start- and restart-disable:

The device is shipped with a jumper between terminals 22 and 23, i.e. the start- and restart-disable is active.

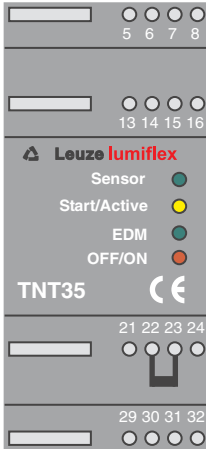

Fig. 4.2-10: Operating mode "with start- and restart-disable"

Without start- and restart-disable:

The start- restart-disable is set to inactive by connecting a jumper between terminals 23 and 24.

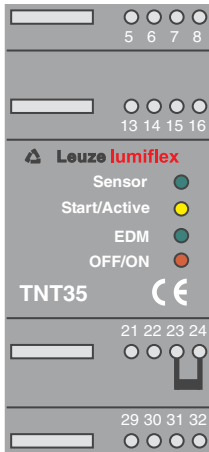

Fig. 4.2-11: Operating mode "without start- and restart-disable"

Completing the setting:

After the setting has been changed, the new device setting must be saved. This is done either by triggering the Reset input (terminal 21) or by switching the supply voltage on and off for a short time.

4.3 Operating states without start- and restart-disable.

Stand-by operation:

The free light path is displayed by the green LED "Sensor".

Activation is not used.

The safety outputs are open. This state is displayed by the red LED.

The display for the relay monitoring (EDM) is active.

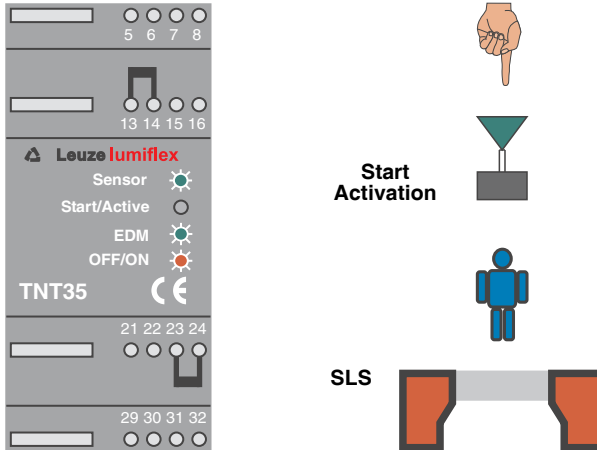

Fig. 4.3-1: Display of the TNT 35 in stand-by operation

Safety operation:

In safety operation, the function of the protective photoelectric sensor is cyclically tested every two seconds. The free safety field is displayed by the green LED.

Activation is used (green LED). The safety output is closed which is displayed by the green LED.

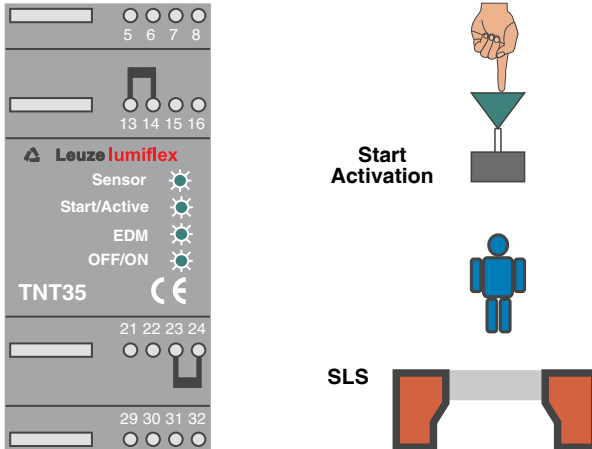

Fig. 4.3-2: Display of the TNT 35 in safety operation

Safety field interruption:

If during safety operation the protective photoelectric sensor is interrupted or the +24V activation signal on the active input is switched off, then the safety output is opened.

After the safety field has been cleared again and the startup test has been completed successfully, the TNT 35 automatically switches the safety relay output back on again.

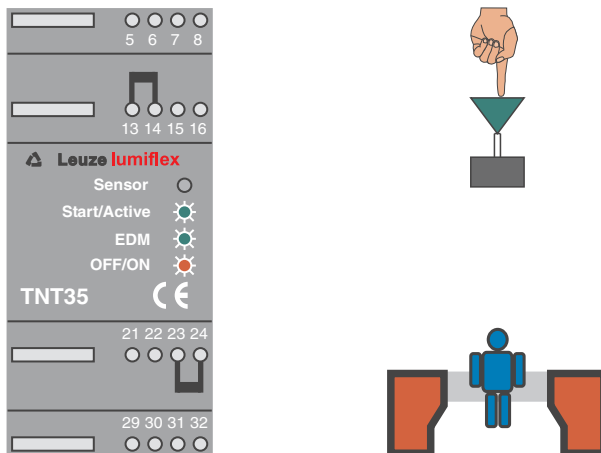

Fig. 4.3-3: Display of the TNT 35 during a safety field interruption

- ① The input for the relay monitoring (terminal 13) always must be wired. For operation without the relay monitoring function, a jumper can be set between terminal 13 and terminal 14.

Connected relays can be monitored if the wiring of the input to terminal 13 is carried out according to the connection diagram "Operation with relay monitoring as EMERGENCY SHUT-DOWN device".

Faulty wiring results in the the safety outputs not switching on. If a fault occurs, the safety outputs switch off with a maximum delay of two seconds.

- ① The activation input must be wired with +24V in order for the safety inputs to switch on!

4.4 Operating states with start- and restart-disable without relay monitoring (EDM)

Stand-by operation:

The free light path is displayed by the green LED "Sensor".

The start input has not been activated.

The safety output is open. This state is displayed by the red LED "OFF/ON". The yellow LED "Start" displays the lock of the start- and restart-disable.

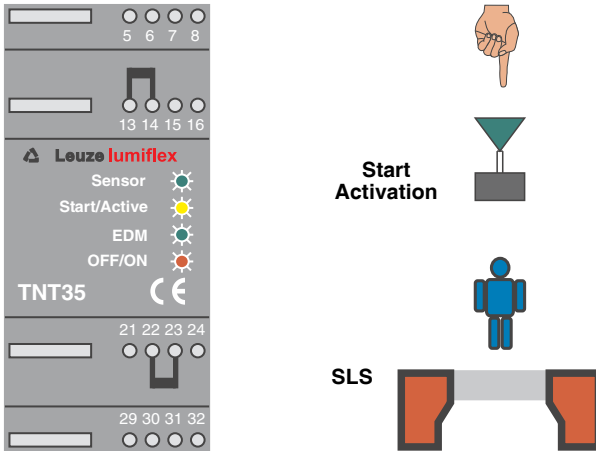

Fig. 4.4-1: Display of the TNT 35 in stand-by operation

Test operation:

In test operation, the proper functioning of both the protective photoelectric sensor and the test monitoring unit is checked.

To induce the test operation, the start input is activated (green LED "Start").

As long as the start-/restart button is pressed, the test operation remains active.

After release of the start-/restart button, the TNT 35 changes from test operation to safety operation.

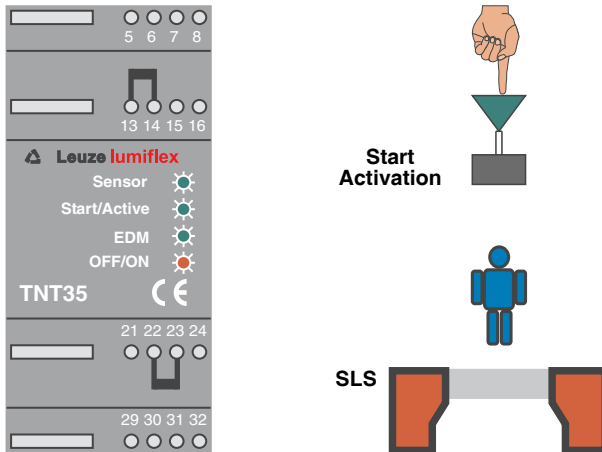

Fig. 4.4-2: Display of the TNT 35 in test operation

Safety operation:

In safety operation, the function of the protective photoelectric sensor is cyclically tested every two seconds. The free safety field is displayed by the green LED "Sensor".

The safety outputs are closed which is displayed by the green LED "OFF/ON".

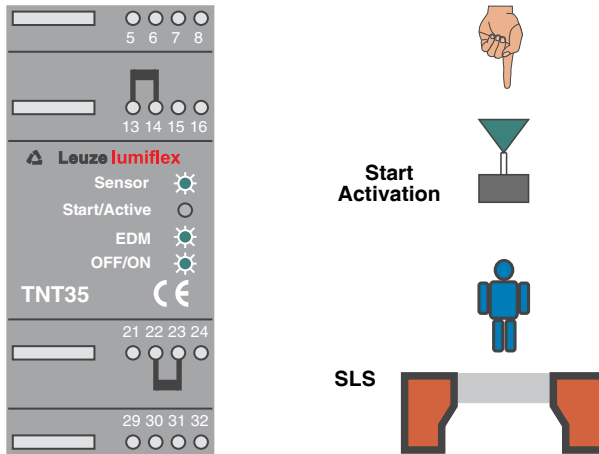

Fig. 4.4-3: Display of the TNT 35 in safety operation

Safety field interruption:

The safety outputs of the TNT 35 are opened (LED "OFF/ON" on red) if during safety operation the light beam of the protective photoelectric sensor is interrupted.

The restart-disable inside the TNT 35 becomes active and prevents an automatic restart of the machine. The yellow LED "Start" displays the function of the restart-disable.

The TNT 35 is in waiting state and can be restarted by pressing the start-/restart button after the safety field is free.

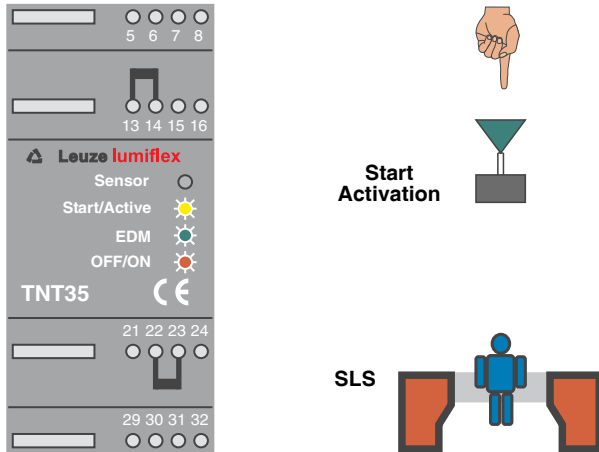

Fig. 4.4-4: Display of the TNT 35 during a safety field interruption

4.5 Operating states with start- and restart-disable and with relay monitoring (EDM)

Stand-by operation:

The free light path is displayed by the green LED "Sensor".

The relay monitoring (EDM) is active (green LED "EDM").

The safety output is open. This state is displayed by the red LED "OFF/ON". The yellow LED "Start" displays the lock of the start- and restart-disable.

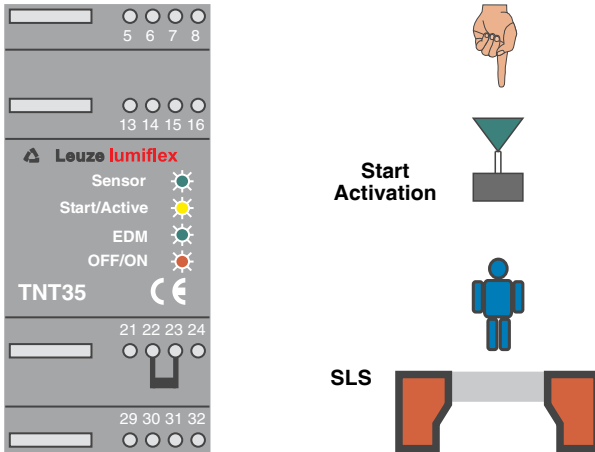

Fig. 4.5-1: Display of the TNT 35 in stand-by operation

Test operation:

In test operation, the proper functioning of both the protective photoelectric sensor and the test monitoring unit is checked.

To induce the test operation, the start input is activated (green LED "Start").

As long as the start-/restart button is pressed, the test operation remains active.

After release of the start-/restart button, the TNT 35 changes from test operation to safety operation.

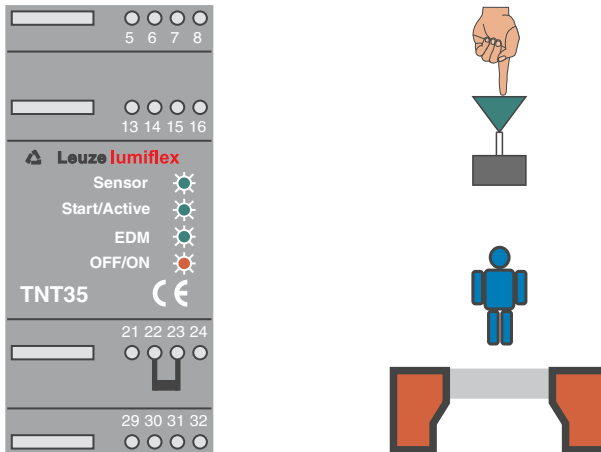

Fig. 4.5-2: Display of the TNT 35 in test operation

Safety operation:

In safety operation, the function of the protective photoelectric sensor is cyclically tested every two seconds. The free safety field is displayed by the green LED "Sensor".

The relay monitoring is inactive in safety operation (green LED "EDM" off).

The safety outputs are closed which is displayed by the green LED "OFF/ON".

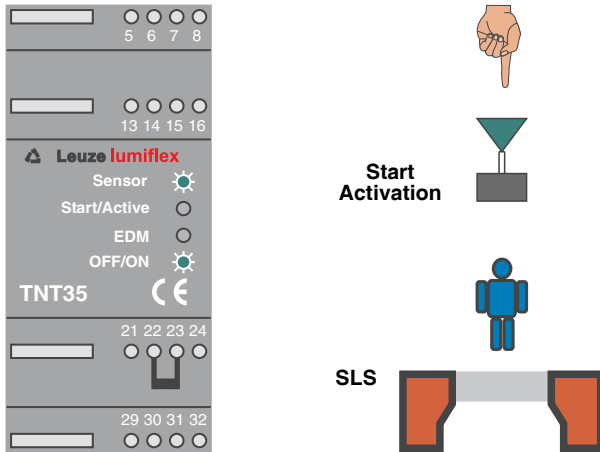

Fig. 4.5-3: Display of the TNT 35 in safety operation

Safety field interruption:

The safety outputs of the TNT 35 are opened (LED "OFF/ON" on red) if during safety operation the light beam of the protective photoelectric sensor is interrupted.

The restart-disable inside the TNT 35 becomes active and prevents an automatic restart of the machine. The yellow LED "Start" displays the function of the restart-disable.

The TNT 35 is in waiting state and can be restarted by pressing the start-/restart button after the safety field is free.

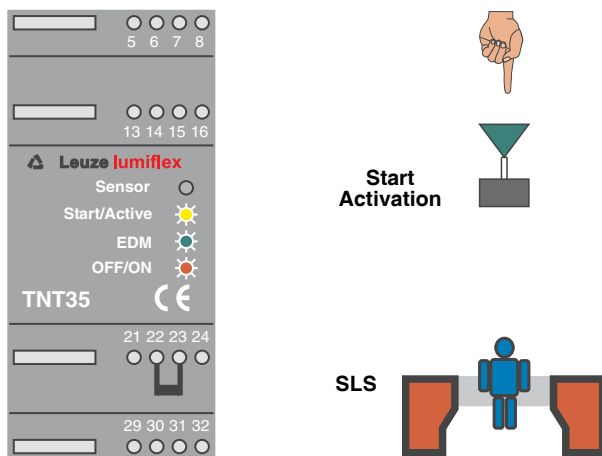

Fig. 4.5-4: Display of the TNT 35 during a safety field interruption

4.6 Fault indication and device reset

Faults of the test monitoring unit TNT 35 are indicated by the blinking of the red "ON/OFF" LED. The possible faults are:

Fault in the operating mode selection:

The selected operating mode of the device at startup (with/without start- and restart-disable) changed during operation. The jumper (terminal 22 to terminal 23 or terminal 23 to terminal 24) should be checked that it is set to the desired operating mode.

Fault in the relay monitoring:

A fault in the wiring or soldered safety contacts was detected by the TNT 35. The wiring and connected contacts should be checked.

Internal device failures:

Equipment faults that are caused by an internal defect result in the unit going into locked state.

Resetting from a locked state:

Resetting from a locked state is carried out by disconnecting the supply voltage for a short time or by applying a reset signal (+24V potential) to the reset input (terminal 21).

The LED will stop blinking after the fault has been eliminated and the device reset from the locked state.

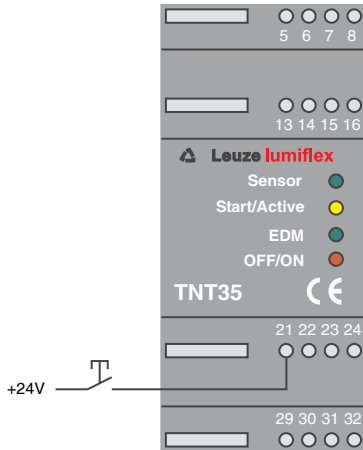

Fig. 4.6-1: Resetting from a locked state

4.7 Technical Data

Electrical data	
Supply voltage U_b	24V DC +/-15 %
Residual ripple	< 15 %
Current consumption	approx. 200 mA
Response time	< 20 ms
Delay before start-up	approx. 2 s

Sensors	
Transmitter activation	PNP (HIGH active)
Receiver input	optical coupler input, input current approx. 10 mA

In- and outputs	
Start input	optical coupler input (High active) input current approx. 10 mA
Reset input	optical coupler input (High active) input current approx. 10 mA
Relay monitoring (EDM)	optical coupler input (High active) input current approx. 10 mA
Message output Safety on	PNP transistor output, 100 mA short circuit- and polarity reversal protection
Message output Error	PNP transistor output, 100 mA short circuit- and polarity reversal protection
Safety output	voltage free make-contact max. switching voltage 250V AC max. current load 4 A
Safeguarding	externally with max. 4 A slow blow
Overvoltage category	2 for rating voltage 300V AC according to VDE 0110 part 1

Environmental data	
Ambient temperature	-20°C - +60°C
Storage temperature	-30°C - +70°C
Protection class	IP 40 (only for application in electrical operating rooms/switching cabinet with minimum protection class IP 54 is suitable)

Impact resistance/Vibration resistance	
EMB/EMV	acc. to EN 61496-1
Contact protection	acc. to VBG 4 and VDE 0106 part 100

Mechanical data	
Housing	Polyamide PA 6.6/grey
Connection	Screw terminals, connection cross-section 0.2 - 2.5 mm
Mounting	snap-on mounting for standard rail according to EN 50022
Weight	approx. 200 g
Dimensions (WxHxD)	45 mm x 100 mm x 115 mm

5 Function and Commissioning of the TNT 35/7-24V

5.1 Function characteristics of the safety system

The TNT 35/7-24V has been designed for mounting on a standard rail in a suitable switching cabinet. The complete safety system consists of a TNT 35/7-24V and accompanying protective photoelectric sensors or light barriers.

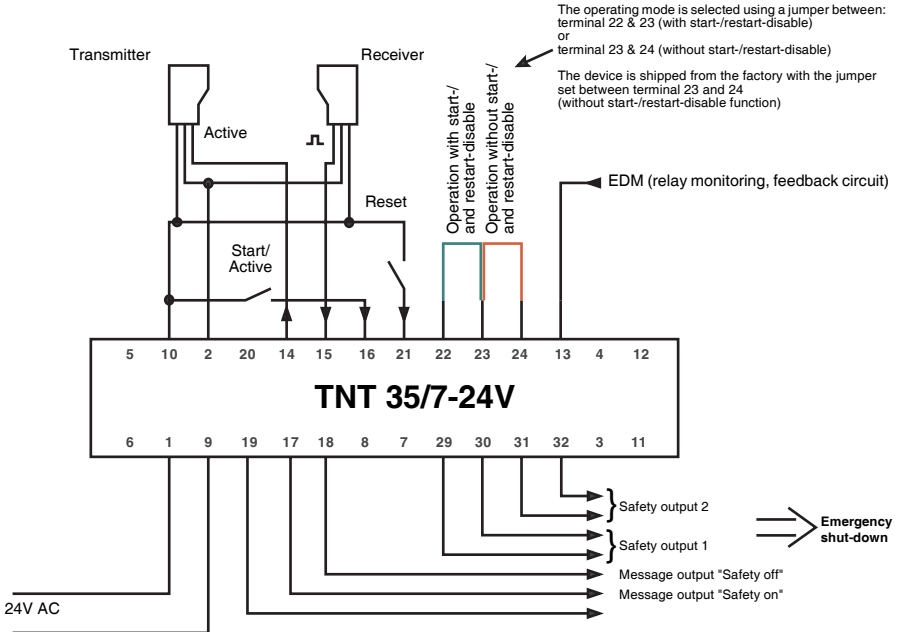

Fig. 5.1-1: Installation of the complete safety system

After the TNT 35/7-24V is switched on via the start input, the functionality of the protective photoelectric sensors is monitored in two-second cycles.

The electrical integration into the control has to be performed acc. to the corresponding safety category acc. to EN 954-1. The voltage free safety relay outputs can be directly used for shut-down of the dangerous movement.

Inside the Test Monitoring unit TNT 35/7-24V, a selectable start- and restart-disable, as well as a selectable relay monitoring input are integrated.

5.1.1 Display and Operating Instruments

The test monitoring unit TNT 35/7-24V features integrated LEDs to indicate the state of the system.

The start- and restart-disable, as well as the relay monitoring functions are set on the TNT 35/7-24 using the corresponding jumpers on the connection terminals.

Overview - Display Elements

- LED "Sensor"
Status of the safety field state
- LED "Start/Active"
Status of the start and activation input
- LED "EDM"
Status of the relay monitoring
- LED "OFF/ON"
Status of the safety circuit (open or closed)

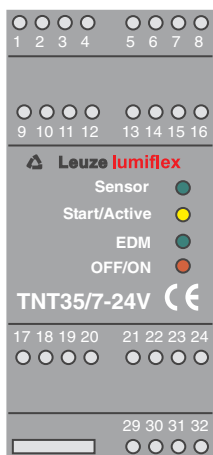

Fig. 5.1-2: Display elements TNT 35/7-24V

5.2 Electrical Installation



The electrical installation is only to be performed by specialised personnel. Supply and signal lines have to be installed separately from power lines during installation. Inside the switching cabinet, suitable spark extinction has to be provided if using contactors. In connection with driving motors and breaks, the corresponding manuals have to be observed.

The power supply for the TNT 35/7-24V must be equipped with a protective mains separation device according to IEC 60742. The power supply unit used to operate the TNT 35/7-24V has to be able to compensate for changes and interruptions of the supply voltage acc. to EN 61496-1.

5.2.1 Supply wiring

The test monitoring unit TNT 35/7-24V is supplied with 24VAC -10/+15%. Current consumption is max. 200mA (without safety sensors). The supply voltage 24V AC is connected to terminals 1 and 9.

5.2.2 Sensor voltage supply

The built-in power supply of the TNT 35/7-24V also supplies the connected safety sensors. A supply voltage of +24VDC is available at terminals 5, 10 and 11. The corresponding GND potential is available on terminals 2, 3 and 6. The maximum current consumption of the safety sensors may not exceed 200 mA.

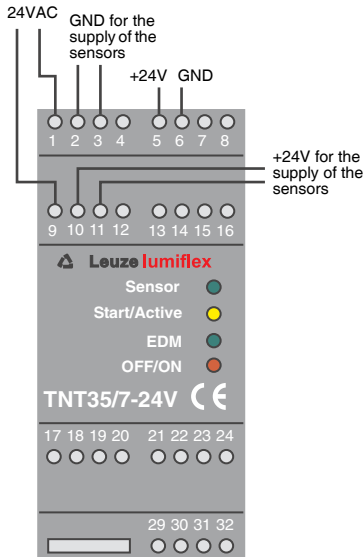

Fig. 5.2-1: Supply wiring



The supply voltage may only be used for the connected safety sensors and the corresponding start and reset signals. Connecting additional components can damage the device!

5.2.3 Start input wiring

The Start input (terminal 16) works both in the operating mode "with start- and restart-disable" and "without start- and restart-disable" in different ways:

- In the operating mode with start- and restart-disable, the TNT 35/7-24V expects two signal changes (push-button function) as switch-on signal. A failure in the start-/restart button, e.g. due to contact malfunction is safely detected by the TNT 35/7-24V.

+24V
Start

A 24V supply terminal (e.g. terminals 5, 10 or 11) can be used for the start signal.

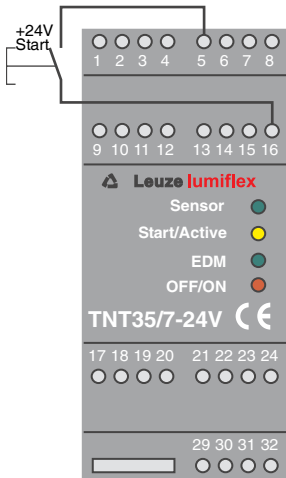

Fig. 5.2-2: Wiring of the start input "with start- and restart-disable"

- In the operating mode without start- and restart-disable, the start input works as activation input. As soon as a HIGH active signal is present at the start input (terminal 16) and the safety field is free, the safety outputs are closed.

A 24V supply terminal (e.g. terminals 5, 10 or 11) can be used for the activation signal.

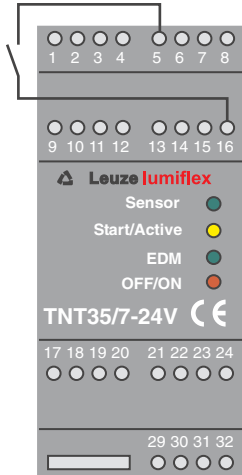

Fig. 5.2-3: Wiring of the start input "without start- and restart-disable"

5.2.4 Wiring of single-beam protective photoelectric sensors

The activation input of the protective photoelectric sensor can be directly connected to terminal 14 on the TNT 35/7-24V.

The switching output of the receiver can be directly connected to terminal 15.

The +24V supply for the safety sensors is taken from the supply terminals 5, 10 and 11, the GND reference potential is taken from terminals 2, 3 and 6.

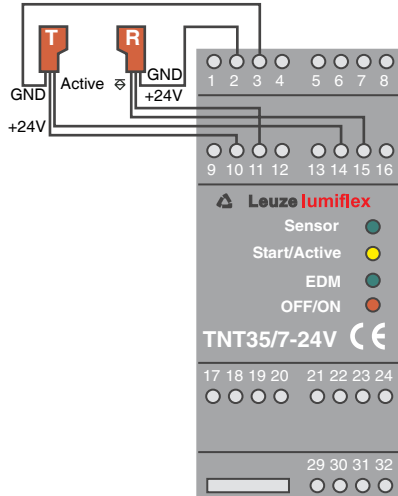

Fig. 5.2-4: Wiring of single-beam protective photoelectric sensors

5.2.5 Wiring of single-beam protective photoelectric sensors in series

Several photoelectric sensor pairs can be connected to the TNT 35/7-24 in series with multi-axle arrangements on a machine or system. The adjacent picture shows a three-axle photoelectric sensor arrangement. It is possible to operate up to **three** photoelectric sensor pairs on one TNT 35/7-24V.

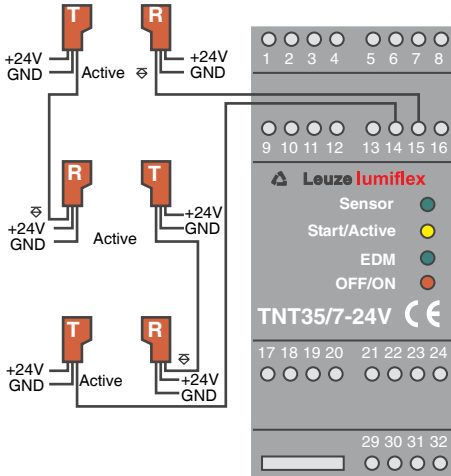

Fig. 5.2-5: Wiring of single-beam protective photoelectric sensors in series

Function characteristics:

The TNT 35/7-24V (terminal 14) activates the first photoelectric sensor transmitter. The receiver is activated via the first optical path and, by using its output, activates the second photoelectric sensor transmitter. The supply has to be provided on each photoelectric transmitter and receiver. The feedback to the TNT 35/7-24V (terminal 15) is done by the last photoelectric sensor receiver within the series connection.

Any time the light axis is interrupted, a message is issued to the TNT 35/7-24V through the series connection.

The series connection tests every transmitter and receiver for function capability while performing the testing procedure.

5.2.6 Wiring safety output

Integration in a one-channel release circuit without relay monitoring

Two safety relay outputs are connected in series. The release circuit can be connected to further components which are then wired to a common EMERGENCY SHUT-DOWN device.

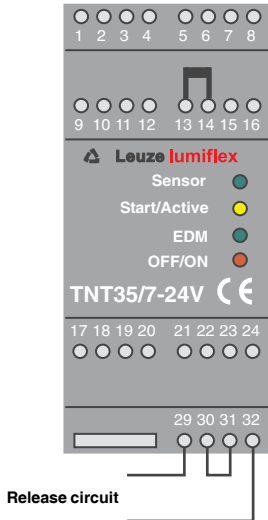

Fig. 5.2-6: Wiring safety output (one-channel release circuit)

Integration in a two-channel release circuit without relay monitoring

Both safety relay outputs are integrated separately into the release circuits. These circuits can be connected with additional components which trigger a common EMERGENCY SHUT-DOWN device.

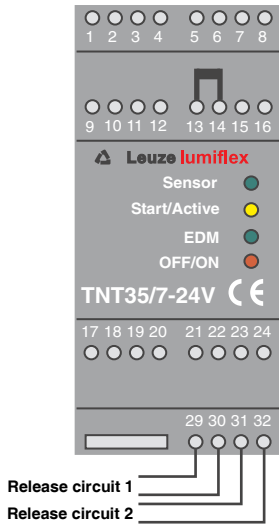

Fig. 5.2-7: Wiring safety output (two-channel release circuit)

Integration with relay monitoring as EMERGENCY SHUT-DOWN device

The motor contactors for dangerous movement are connected to both safety relay outputs. For this purpose, forced contactors have to be used. In the connection diagram, no fuses are included. However, for correct function fuses are absolutely required. The maximum contact load of the safety relay outputs is 4A with 24VDC.

The supply of the relay monitoring (EDM) is made from the supply terminals 5, 10 or 11.

Control of the motor contactors happens via K1 and K2. If a contact of K1 and K2 should fuse together, a message is issued to the TNT 35/7-24V through the feedback circuit (EDM). A new start of the unit is possible only after removal of the failure in the output circuit.

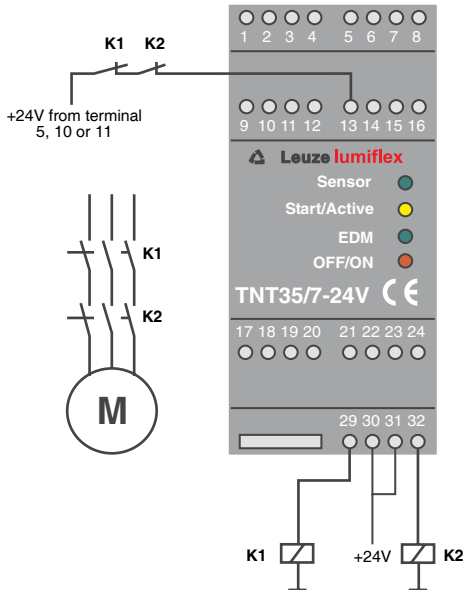

Fig. 5.2-8: Wiring of the safety output with relay monitoring

5.2.7 Wiring of the message outputs

Two message outputs are integrated in the TNT 35/7-24V. Both are high-active, positive switching semiconductor outputs and can be connected to potential free inputs of an SPS. This requires connection to the GND potential of terminal 2, 3 or 6 as reference.



The reference potential on terminals 2, 3 and 6 may not be connected with the GND potential of the machine or the controller. A faulty connection can damage the device!

The Message output "Safety" is a potential free relay output. The relay actuation input is at terminal 17. The make-contact (terminal 19) is always active when the safety outputs are closed. The break-contact (terminal 18) is active if the safety outputs are open.

The message output "Error" is always active if the TNT 35/7-24V detects an error. Those errors can be internal or external.

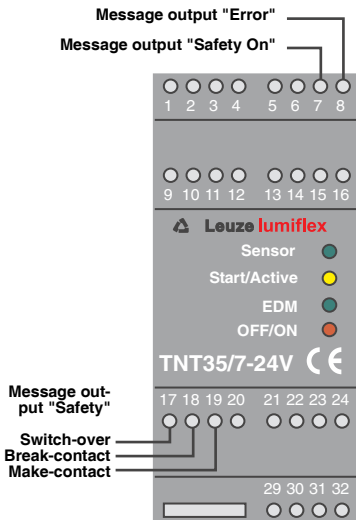

Fig. 5.2-9: Wiring of the message outputs



The message outputs on terminals 17, 18 and 19 are only approved for 24V DC operation. Do not connect to higher voltages!

5.2.8 Setting of the operating mode

The start- and restart-disable function is selected on the device by setting a jumper between terminals 22 and 23 or terminals 23 and 24.



Terminals 22, 23 and 24 may only be used to for selecting the operating mode using the included short circuit jumpers.

With start- and restart-disable:

The device is shipped with a jumper between terminals 22 and 23, i.e. the start- and restart-disable is active.

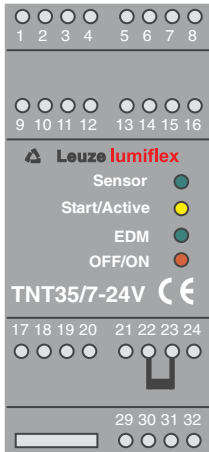

Fig. 5.2-10: Operating mode "with start- and restart-disable"

Without start- and restart-disable:

The start- and restart-disable is set to inactive by connecting a jumper between terminals 23 and 24.

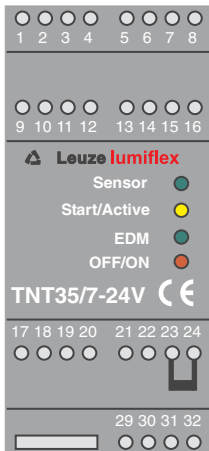

Fig. 5.2-11: Operating mode "with start- and restart-disable"

Completing the setting:

After the setting has been changed, the new device setting must be saved. This is done either by triggering the Reset input (terminal 21) or by switching the supply voltage on and off for a short time.

5.3 Operating states without start- and restart-disable.

Stand-by operation:

The free light path is displayed by the green LED "Sensor".

Activation is not used. The safety outputs are open. This state is displayed by the red LED.

The display for the relay monitoring (EDM) is active.

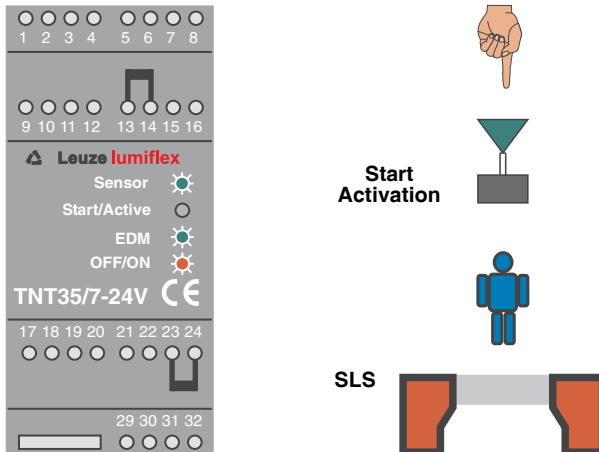

Fig. 5.3-1: Display of the TNT 35/7-24V in stand-by operation

Safety operation:

In safety operation, the function of the protective photoelectric sensor is cyclically tested every two seconds. The free safety field is displayed by the green LED.

Activation is used (green LED). The safety output is closed which is displayed by the green LED.

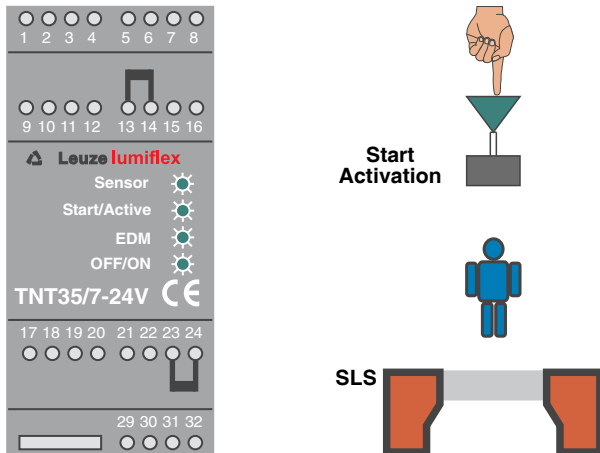

Fig. 5.3-2: Display of the TNT 35/7-24V in safety operation

Safety field interruption:

If during safety operation the protective photoelectric sensor is interrupted or the +24V activation signal on the active input is switched off, then the safety output is opened.

After the safety field has been cleared again and the startup test has been completed successfully, the TNT 35/7-24V automatically switches the safety relay output back on again.

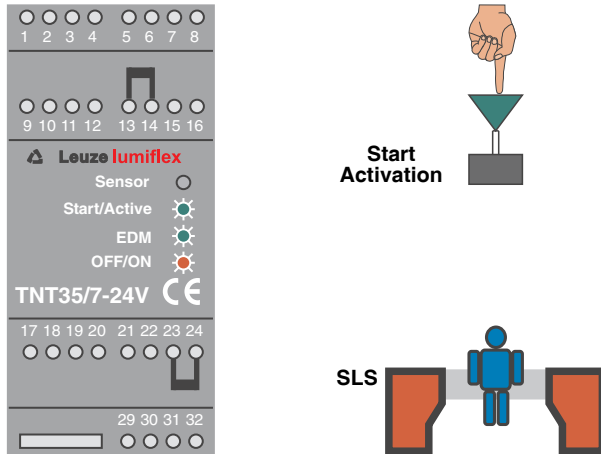

Fig. 5.3-3: Display of the TNT 35/7-24V during a safety field interruption

- ① The input for the relay monitoring (terminal 13) always must be wired. For operation without the relay monitoring function, a jumper can be set between terminal 13 and terminal 14.

Connected relays can be monitored if the wiring of the input to terminal 13 is carried out according to the connection diagram "Operation with relay monitoring as EMERGENCY SHUT-DOWN device".

Faulty wiring results in the safety outputs not switching on. If a fault occurs, the safety outputs switch off with a maximum delay of two seconds.

- ① The activation input must be wired with +24V in order for the safety inputs to switch on!

5.4 Operating states with start- and restart-disable without relay monitoring (EDM)

Stand-by operation:

The free light path is displayed by the green LED "Sensor".

The start input has not been activated.

The safety output is open. This state is displayed by the red LED "OFF/ON". The yellow LED "Start" displays the lock of the start- and restart-disable.

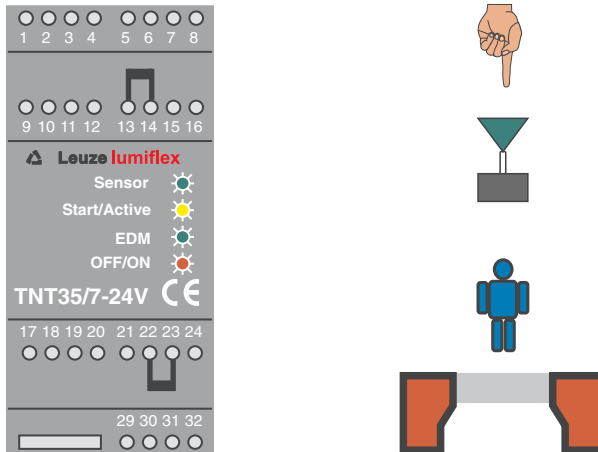

Fig. 5.4-1: Display of the TNT 35/7-24V in stand-by operation



For the operating mode without relay monitoring, the jumper that short-circuits terminals 13 and 14 **must** be set.

Test operation:

In test operation, the proper functioning of both the protective photoelectric sensor and the test monitoring unit is checked.

To induce the test operation, the start input is activated (green LED "Start").

As long as the start-/restart button is pressed, the test operation remains active.

After release of the start-/restart button, the TNT 35/7-24V changes from test operation to safety operation.

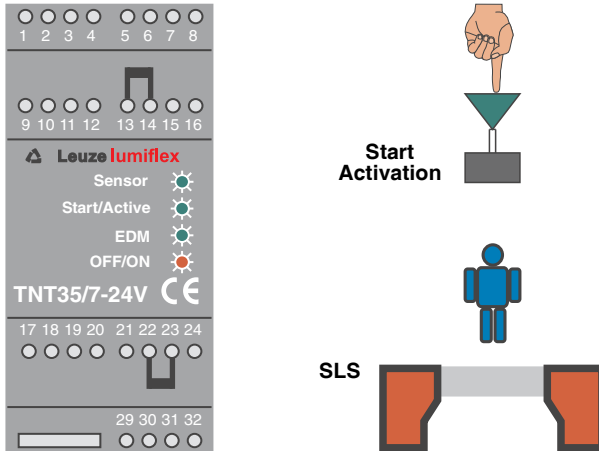

Fig. 5.4-2: Display of the TNT 35/7-24V in test operation



For the operating mode without relay monitoring, the jumper that short-circuits terminals 13 and 14 **must** be set.

Safety operation:

In safety operation, the function of the protective photoelectric sensor is cyclically tested every two seconds. The free safety field is displayed by the green LED "Sensor".

The safety outputs are closed which is displayed by the green LED "OFF/ON".

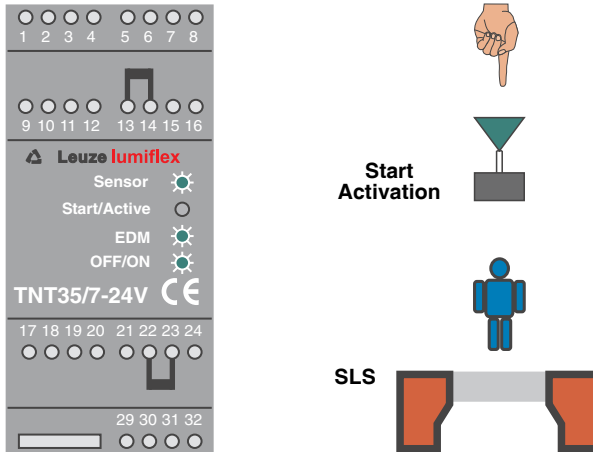

Fig. 5.4-3: Display of the TNT 35/7-24V in safety operation

Safety field interruption:

The safety outputs of the TNT 35/7-24V are opened (LED "OFF/ON" on red) if during safety operation the light beam of the protective photo electric sensor is interrupted.

The restart-disable inside the TNT 35/7-24V becomes active and prevents an automatic restart of the machine. The yellow LED "Start" displays the function of the restart-disable.

The TNT 35/7-24V is in waiting state and can be restarted by pressing the start/restart button after the safety field is free.

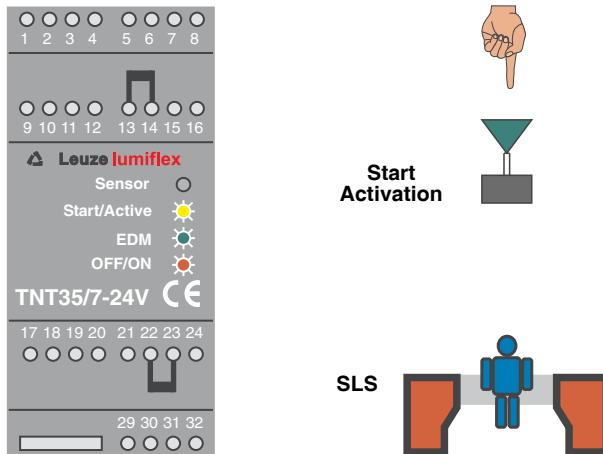

Fig. 5.4-4: Display of the TNT 35/7-24V during a safety field interruption

5.5 Operating states with start- and restart-disable and with relay monitoring (EDM)

Stand-by operation:

The free light path is displayed by the green LED "Sensor".

The relay monitoring (EDM) is active (green LED "EDM").

The safety output is open. This state is displayed by the red LED "OFF/ON". The yellow LED "Start" displays the lock of the start- and restart-disable.

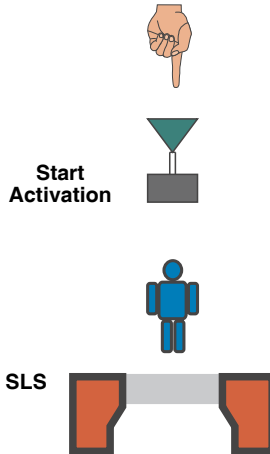
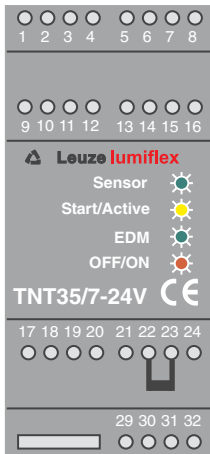

Fig. 5.5-1: Display of the TNT 35/7-24V in stand-by operation

Test operation:

In test operation, the proper functioning of both the protective photoelectric sensor and the test monitoring unit is checked.

To induce the test operation, the start input is activated (green LED "Start").

As long as the start-/restart button is pressed, the test operation remains active.

After release of the start-/restart button, the TNT 35/7-24V changes from test operation to safety operation.

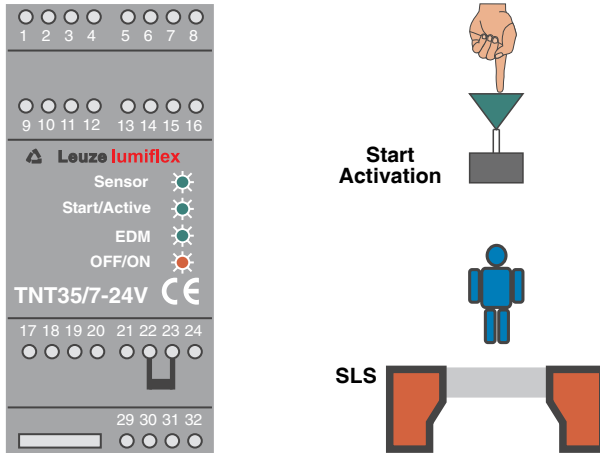

Fig. 5.5-2: Display of the TNT 35/7-24V in test operation

Safety operation:

In safety operation, the function of the protective photoelectric sensor is cyclically tested every two seconds. The free safety field is displayed by the green LED "Sensor".

The relay monitoring is inactive in safety operation (green LED "EDM" off).

The safety outputs are closed which is displayed by the green LED "OFF/ON".

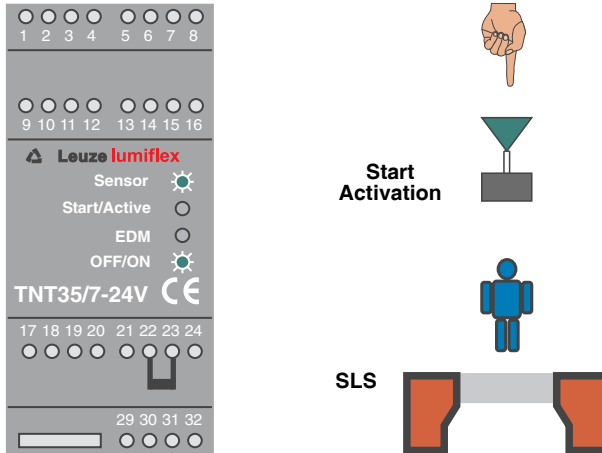

Fig. 5.5-3: Display of the TNT 35/7-24V in safety operation

Safety field interruption:

The safety outputs of the TNT 35/7-24V are opened (LED "OFF/ON" on red) if during safety operation the light beam of the protective photo electric sensor is interrupted.

The restart-disable inside the TNT 35/7-24V becomes active and prevents an automatic restart of the machine. The yellow LED "Start" displays the function of the restart-disable.

The TNT 35/7-24V is in waiting state and can be restarted by pressing the start/restart button after the safety field is free.

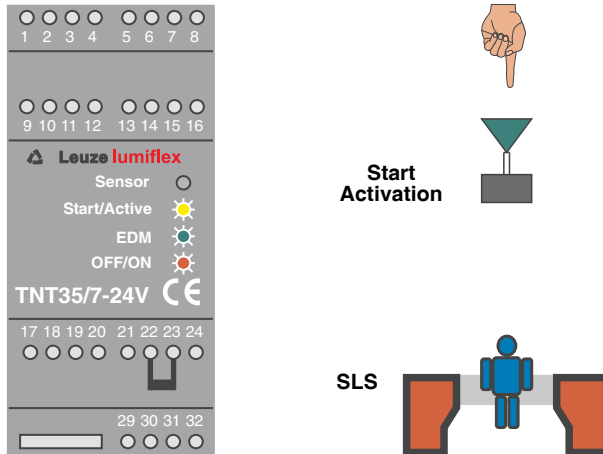

Fig. 5.5-4: Display of the TNT 35/7-24V during a safety field interruption

5.6 Fault indication and device reset

Faults of the test monitoring unit TNT 35/7-24 are indicated by the blinking of the red "ON/OFF" LED. The possible faults are:

Fault in the operating mode selection:

The selected operating mode of the device at startup (with/without start- and restart-disable) changed during operation. The jumper (terminal 22 to terminal 23 or terminal 23 to terminal 24) should be checked that it is set to the desired operating mode.

Fault in the relay monitoring:

A fault in the wiring or soldered safety contacts was detected by the TNT 35/7-24. The wiring and connected contacts should be checked.

Internal device failures:

Equipment faults that are caused by an internal defect result in the unit going into locked state.

Resetting from a locked state:

Resetting from a locked state is carried out by disconnecting the supply voltage for a short time or by applying a reset signal (+24V potential) to the reset input (terminal 21). The +24V potential for the reset signal can be taken from terminals 5, 10 or 11.

The LED will stop blinking after the fault has been eliminated and the device reset from the locked state.

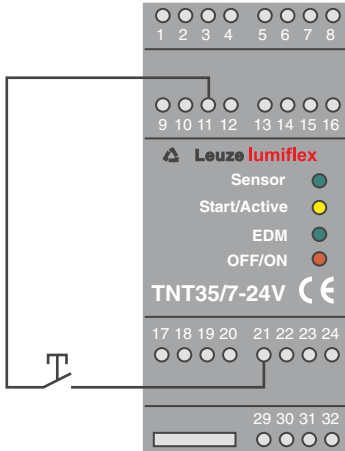

Fig. 5.6-1: Resetting from a locked state

5.7 Technical Data

Electrical data	
Supply voltage U_b	24V AC +15 %/-10 %
Frequency	50 Hz/60 Hz
Current consumption	approx. 200 mA
Response time	< 20 ms
Delay before start-up	approx. 2 s

Sensors	
Transmitter activation	PNP (HIGH active)
Receiver input	optical coupler input, input current approx. 10 mA
Sensor voltage supply	24V DC, max. 200 mA

In- and outputs	
Start input	optical coupler input (High active) input current approx. 10 mA
Reset input	optical coupler input (High active) input current approx. 10 mA
Relay monitoring (EDM)	optical coupler input (High active) input current approx. 10 mA
Message output "Safety on"	PNP transistor output, 100 mA short circuit- and polarity reversal protection
Message output "Safety"	potential free relay contacts max. switching voltage 24V DC make-contact/break-contact combination max. current load 4 A at 24V DC
Message output "Error"	PNP transistor output, 100 mA short circuit- and polarity reversal protection
Safety output	voltage free make-contact max. switching voltage 250V AC max. current load 4A
Safeguarding	externally with max. 4 A slow blow
Overvoltage category	2 for rating voltage 300V AC according to VDE 0110 part 1

Environmental data	
Ambient temperature	-20°C - +60°C
Storage temperature	-30°C - +70°C
Protection class	IP 40 (only for application in electrical operating rooms/switching cabinet with minimum protection class IP 54 is suitable)

Impact resistance/Vibration resistance	
EMB/EMV	acc. to EN 61496-1
Contact protection	acc. to VBG 4 and VDE 0106 part 100

Mechanical data	
Housing	Polyamide PA 6.6/grey
Connection	Screw terminals, connection cross-section 0.2 - 2.5 mm
Mounting	snap-on mounting for standard rail according to EN 50022
Weight	approx. 300 g
Dimensions (WxHxD)	45 mm x 100 mm x 115 mm

6 Applications

In the following chapter, a number of examples of applications are given, which illustrate the wide application areas of the TNT 35 and TNT 35/7-24V.

6.1 Example with retro-reflective photoelectric safety sensor SRK 96

Up to three SRK 96 retro-reflective photoelectric safety sensors can be connected in series directly to the TNT 35. The supply of the retro-reflective photoelectric safety sensors comes directly from the power supply of the installation/machine. Test monitoring of the photoelectric sensors is carried out by the TNT 35.

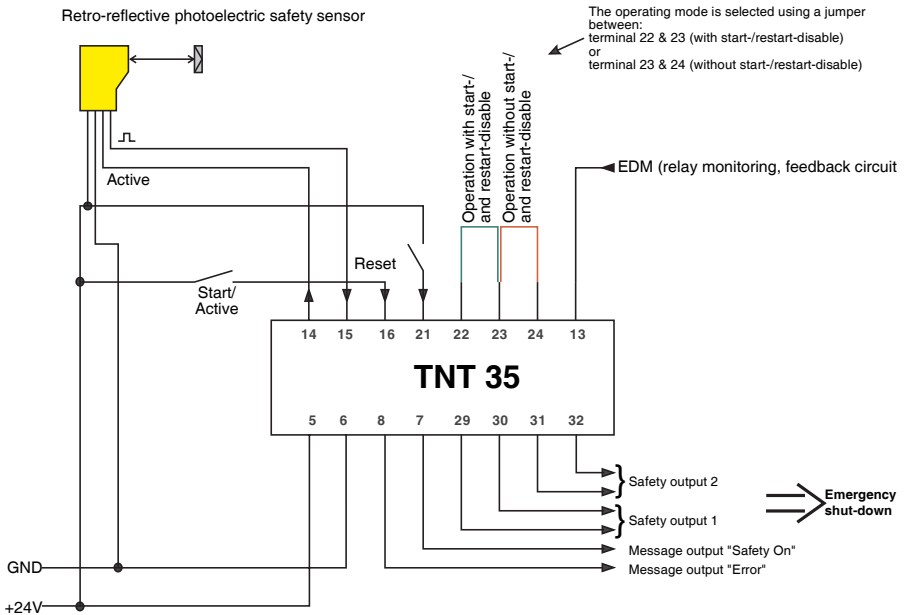

Fig. 6.1-1: Connection diagram for connecting an SRK 96

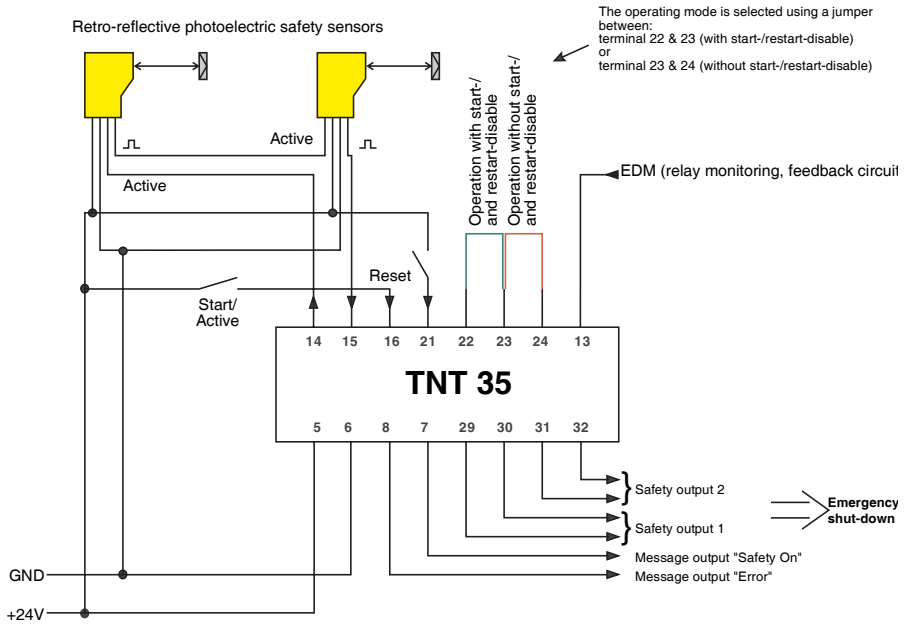

Fig. 6.1-2: Connection diagram for connecting two SRK 96s

6.2 Example with a protective photoelectric sensor SLS 96 ...

Up to six pairs of SLS 96 protective photoelectric sensors can be connected in series directly to the TNT 35. The supply of the protective photoelectric sensors comes directly from the power supply of the installation/machine. Test monitoring of the photoelectric sensors is carried out by the TNT 35.

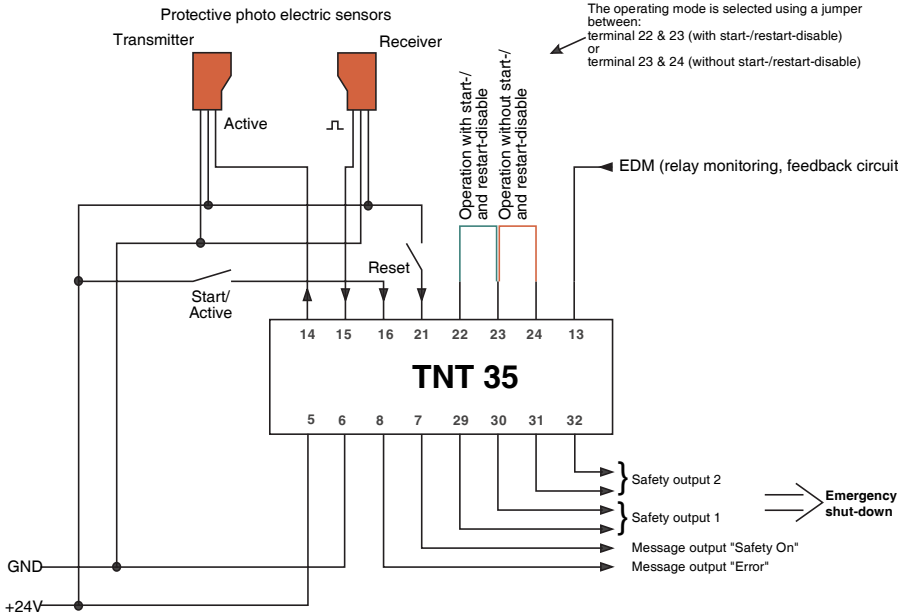

Fig. 6.2-1: Connection diagram for a pair of SLS 96s

6.3 Example with a protective light barrier ECO

Up to three pairs of protective photoelectric barriers of type ECO can be connected in series directly to the TNT 35. The supply of the protective photoelectric barriers comes directly from the power supply of the installation/machine. Test monitoring of the photoelectric barriers is carried out by the TNT 35.

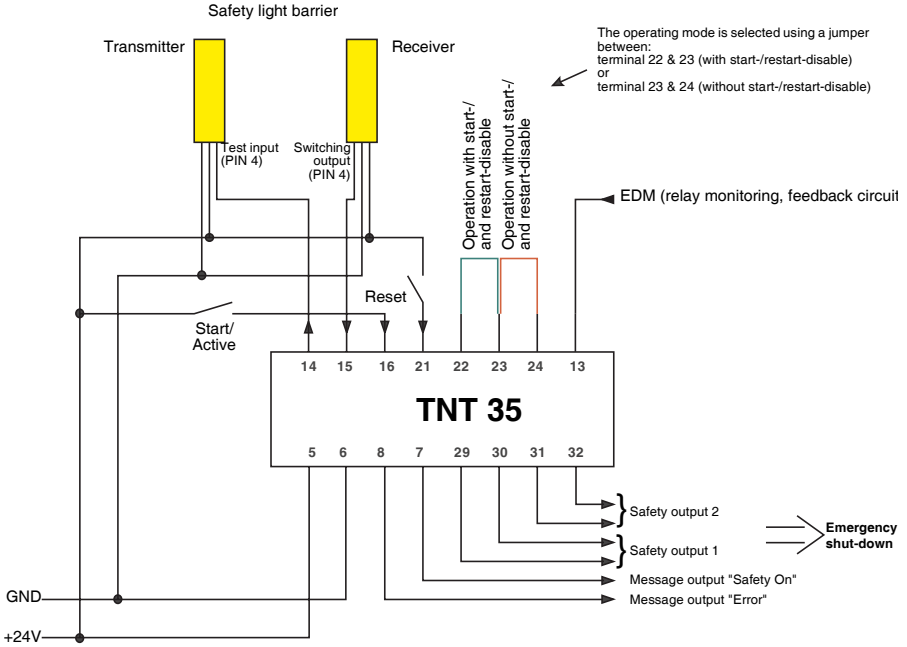

Fig. 6.3-1: Connection diagram for a pair of ECOs

6.4 Example with a protective photoelectric barrier ROBUST

Up to six pairs of ROBUST 22 protective photoelectric barriers or up to two pairs of ROBUST 23 protective photoelectric barriers can be connected in series directly to the TNT 35. The supply of the protective photoelectric barriers comes directly from the power supply of the installation/machine. Test monitoring of the photoelectric barriers is carried out by the TNT 35.

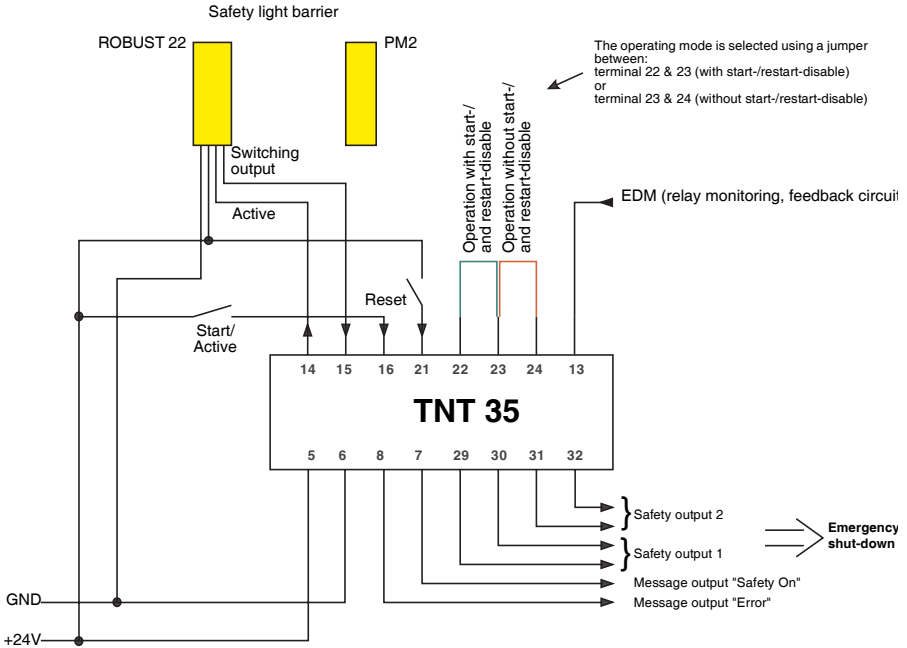

Fig. 6.4-1: Connection diagram for connecting a ROBUST 22

6.5 Example of a TNT 35 with protective photoelectric sensor SLS 96 and EMERGENCY SHUT-DOWN function

In certain situations (with simple machines), the TNT 35 can also function as a EMERGENCY SHUT-DOWN module. Up to six pairs of SLS 96 protective photoelectric sensors can be connected in series directly to the TNT 35. The supply of the protective photoelectric sensors comes directly from the power supply of the installation/machine. Test monitoring of the photoelectric sensors is carried out by the TNT 35. The EMERGENCY SHUT-DOWN button(s) can be wired into the voltage supply of the TNT 35. If an EMERGENCY SHUT-DOWN situation occurs, the TNT 35 will be disconnected from its voltage supply, resulting in the outputs switching off. The dangerous motion will be stopped.

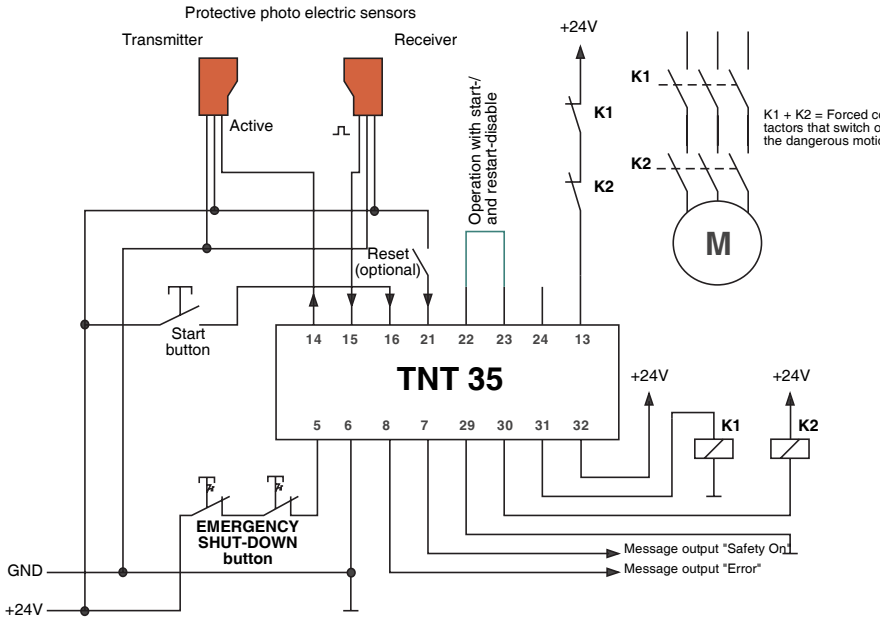

Fig. 6.5-1: Connection diagram with a protective photoelectric sensor SLS 96 and EMERGENCY SHUT-DOWN function



The maximum fall-delay time of the relay can be up to 130 ms! This time must be included in the calculation of the safety distances!

6.6 Example of a TNT 35/7-24V with a retro-reflective photoelectric safety sensor SRK 96

Up to three SRK 96 retro-reflective photoelectric safety sensors can be connected in series directly to the TNT 35/7-24V. The supply of the retro-reflective photoelectric safety sensors comes directly from the TNT 35/7-24V.

Test monitoring of the photoelectric sensors is carried out by the TNT 35/7-24.

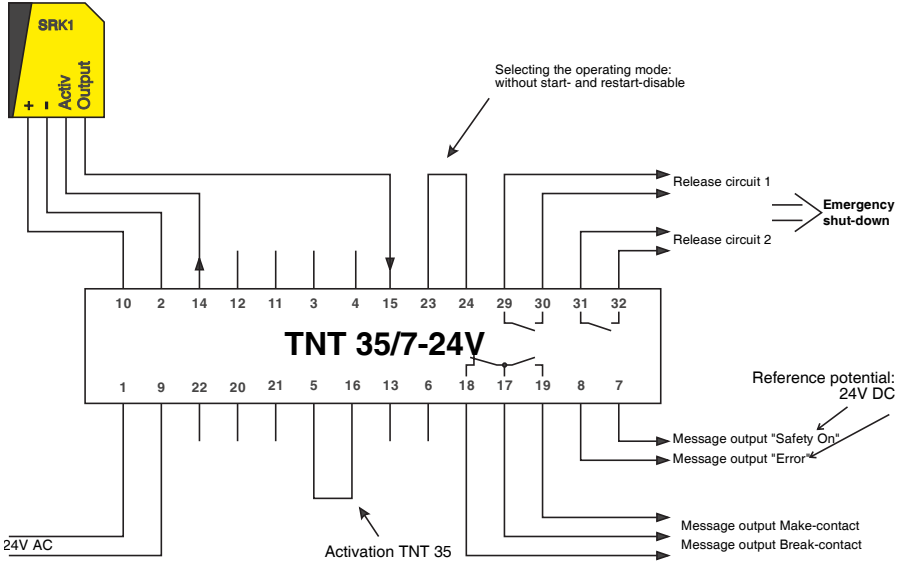

Fig. 6.6-1: Connection diagram for connecting an SRK 96



In the above example, the start- and restart-disable function is deactivated. The start- and restart-disable function must be activated or deactivated depending on the application.

6.7 Example of a TNT 35/7-24V with two retro-reflective photoelectric safety sensors SRK 96

Up to three SRK 96 retro-reflective photoelectric safety sensors can be connected in series directly to the TNT 35/7-24V. The supply of the retro-reflective photoelectric safety sensors comes directly from the TNT 35/7-24V.

Test monitoring of the photoelectric sensors is carried out by the TNT 35/7-24.

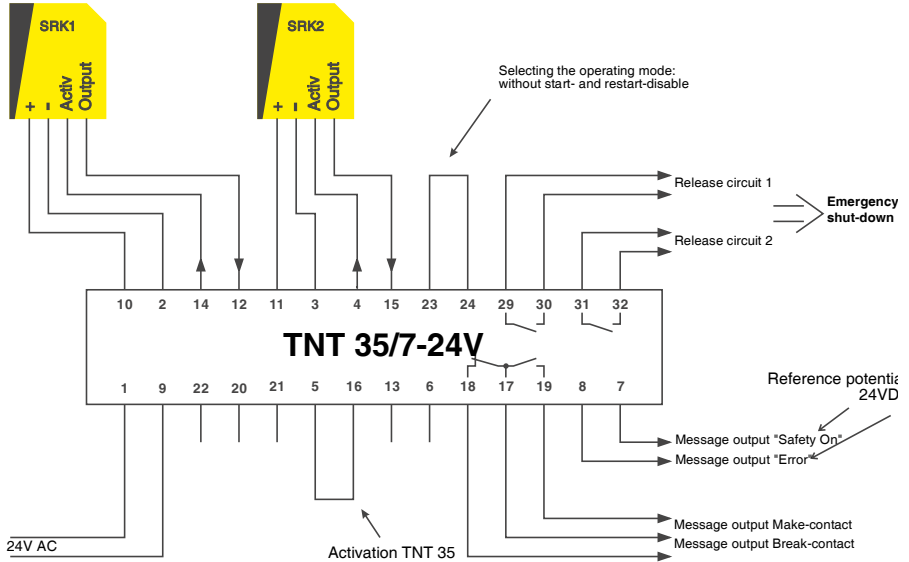

Fig. 6.7-1: Connection diagram for connecting two SRK 96s



In the above example, the start- and restart-disable function is deactivated. The start- and restart-disable function must be activated or deactivated depending on the application.

7 Appendix

7.1 Remaining Risks (EN 292-1)

The circuit proposals as shown in this manual have been tested and checked with the highest possible care. The current standards and guidelines are fulfilled if using the shown components and the corresponding wiring. Remaining risks are present if:

- the proposed circuit concept is changed and the connected safety-relevant components or protective devices are possibly not or insufficiently included in the safety circuit.
- the user did not comply with the current safety regulations for operation, adjustment and maintenance of the machine. Strict compliance with the intervals for checking and maintenance of the machine is mandatory.

