

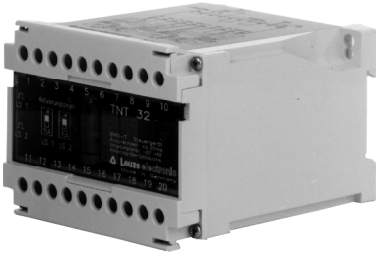

TNT 32



Test monitoring unit



Safety note:

- The test monitoring unit TNT 32 is an electro sensitive protective device (ESPE) category 2 according to prEN 50100-1, only in connection with an EC certified protective photoelectric sensor (AOPD category 2).

Accessories

(available separately)

- EC model tested throughbeam protective photoelectric sensors of the series:
 - 46 Series
 - 78 Series
 - 85 Series
 - 92 Series
 - 95 Series
 - 96 Series
 - 763 Series

Features

- Connection possibility for all throughbeam protective photoelectric sensors (AOPD category 2) with test or activation input
- Starting test with 2 channel test input
- 2 channel output with forced security relay contacts
- Integrated start and restart-disable

Dimensional Drawing

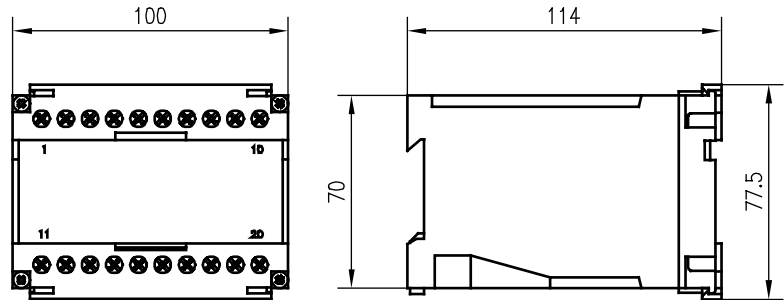

Electrical Connection

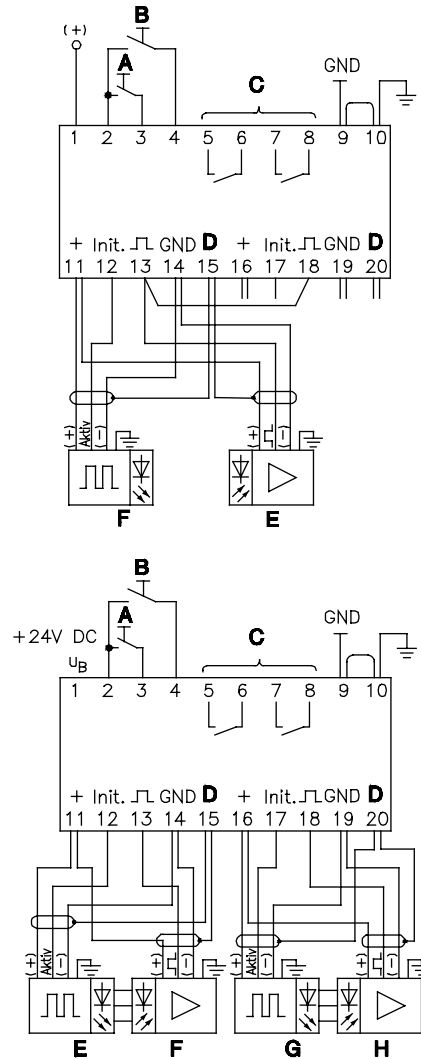

- | | |
|------------------|---------------|
| A Test 1 | E Re 1 |
| B Test 2 | F Tr 1 |
| C Outputs | G Re 2 |
| D Shield | H Tr 2 |

606701 - 08/05 A000 Subject to change without prior notice



Leuze lumiflex GmbH + Co.KG
 Liebigstraße 4
 D-82256 Fürstenfeldbruck, Germany
 Tel: +49 8141 5350-0
 Fax: +49 8141 5350-190
 e-mail: lumiflex@leuze.de
 www.leuze.com



Technical Data

Supply	
Operating voltage U_B	24V DC
Residual ripple	$\leq 15\%$ of U_B
Current consumption	approx. 200mA
Response time	≤ 20 ms
Test inputs	
Voltage	+ U_B (active high)
Current	≤ 25 mA
Pulse duration	≥ 60 ms
Outputs	
2 voltage free relay contacts (make-contact)	
Switching voltage	220V AC 10 ... 60V DC
Switching current	2.0A 2A (resistive load)
Fuse	2A MT
Mechanical data	
Dimensions	100x77,5x114mm (WxHxD)
Weight	approx. 470g
Housing	polycarbonate, cover ABS/v-o gray
Connection	screw connections 2x2.5mm ² acc. to DIN 46288
Mounting type	snap-on mounting for standard rail
Environmental data	
Ambient temp. (operating/storage)	-20°C ... +60°C/-30°C ... +70°C
Protection class	IP 40 (only for application in electrical operating rooms/ switching cabinet with minimum protection class IP 54 is suitable)

Order guide

Designation	Part No.
TNT 32	500 20476

Tables

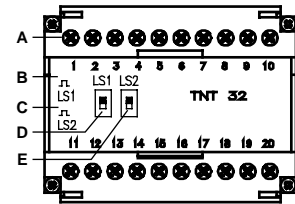

- A Connection terminals
- B Status display light barrier 1
- C Status display light barrier 2
- D Selector switch activation level light barrier LS1
- E Selector switch activation level light barrier LS2