

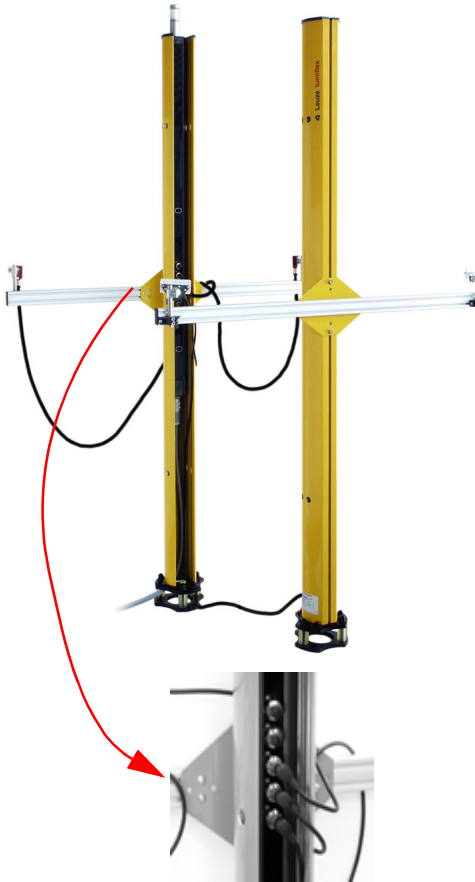

Mounting Instructions



CPSET-M05/-M06

Required tools:

- 3,4 and 6 mm Allen-type wrench
- 10 mm socket wrench with max. 16 mm outside diameter
- 16 mm hexagonal wrench
- 17 mm hexagonal wrench
- Spirit level
- Electric drill with a 10 mm stone drill bit

Special settings for CPRT500/2-mxL01/R2

- Output „OSSD-state“ at M3 (red)
- Activation of internal start/restart interlock, start button at L5 or M1
- Muting time limit infinite



Leuze lumiflex GmbH + Co. KG
 Liebigstraße 4
 D-82256 Fürstfeldbruck, Germany
 Tel. +49 8141 5350-0
 Fax +49 8141 5350-190
 e-mail: lumiflex@leuze.de
 www.leuze.com

Procedure

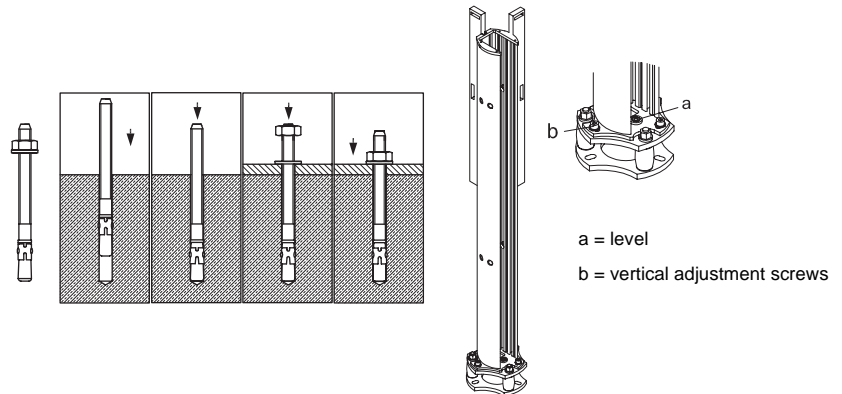

1. The devices come already mounted in the device column UDC. The mounting height can be adjusted by loosening the screws at the side.
2. Determine the mid-points for mounting the columns and mark them on the floor.
3. Start at the mid-points, mark the connecting lines on the floor for a length of approx. 90 mm.
4. Place the drill template on each mid-point, orienting it according to the connecting lines. Mark the hole positions.
5. Drill mounting holes 80 mm deep and insert floor braces.
6. Set the columns, screw them firmly into place and adjust roughly using the level (a). Using the adjustment screws (b), adjust the vertical position of the device columns using the spirit level.
7. Fix the passive reflector holder MMS-P at the vertical slot at the back side of the device column with the deflection mirror CPM.
8. Fix MMS-A, the pre-assembled muting sensor holder, at the vertical slot at the back side of the device column with the receiver CPR.
9. Connect the muting sensor cables to the sockets X2 and X3 of the receiver CPR.
10. Connect the cable with a 12-pin plug to the machine interface /R2 of the receiver, integrate the safety outputs in the machine control circuit and connect power supply (brown: 24VDC, rose: 0VDC, green/yellow: earth; red: M3).
11. Pre-adjust muting sensor and reflector holders MMS so, that on simultaneous interruption of both beams the muting object (box, palette, ..) can be safely distinguished from persons entering the danger area.
12. Switch on the devices and ensure that they are adjusted appropriately. Optimum adjustment has been achieved when the orange weak signal indicator on the devices is not lit up.
13. Adjust muting sensors at their corresponding reflectors. On interruption of both beams, the integrated LED muting indicator lights up.

