



## Mounting Instructions



### CPSET-M07/-M08

#### Required tools:

- 3,4 and 6 mm Allen-type wrench
- 10 mm socket wrench with max. 16 mm outside diameter
- 16 mm hexagonal wrench
- 17 mm hexagonal wrench
- Spirit level
- Electric drill with a 10 mm stone drill bit

#### Special settings for CPRT500/2-mxl02/R2

- Output „OSSD-state“ at M3 (red)
- Activation of internal start/restart interlock, start button at L5 or M1
- Muting time limit infinite



**Leuze lumiflex GmbH + Co. KG**  
 Liebigstrasse 4  
 D-82256 Fürstfeldbruck, Germany  
 Tel: +49 8141 5350-0  
 Fax: +49 8141 5350-190  
 E-Mail: lumiflex@leuze.de  
 www.leuze.com

## Procedure

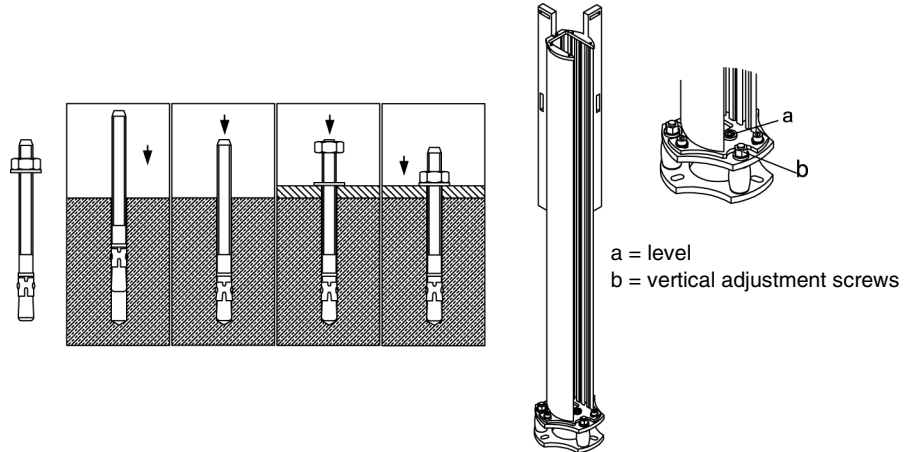

1. The devices come already mounted in the UDC device column. The mounting height can be adjusted by loosening the screws on the column.
2. Find the midpoints for mounting the columns and mark them on the floor.
3. Starting at the midpoints, mark the connecting lines on the floor approx. 90 mm long.
4. Place the drill template on the midpoints and align it with the connecting lines. Mark the hole positions.
5. Drill mounting holes 80 mm deep and insert foundation bolts.
6. Set up the columns, screw them firmly into place and adjust roughly using the level (a). Using the adjustment screws (b), adjust the vertical position of the columns with the spirit level.
7. Fix MMS-A, the bracket with mounted muting sensors, on the vertical slot at the rear of the column.
8. Connect the muting sensors to the connection sockets X1 to X4 of the receiver, CPRT (as in figure below).
9. Connect the cable to the machine interface/R2; integrate safety switching outputs into the machine control and connect power supply lead (brown: 24VDC; pink: 0VDC; green/yellow: earth; red: M3).
10. Align sensor brackets (MMS-A) and muting sensors so that when activated at the same time, the opposing light scanners can safely distinguish between the transport material and people entering the danger area.
11. Switch on the devices and check that they are correctly aligned. Optimum alignment is achieved when the orange weak signal indicator on the receiver is no longer lit up.
12. Align muting sensors. The integrated muting lamp lights up when the opposing light scanner is activated at the same time.

