



## KONTURflex

### QUATTRO-CANopen

Connecting and Operating Instructions



## Notes on Connecting and Operating Instructions

This additional connecting and operating instructions contain the description of the CANopen Interface for the KONTURflex CANopen Device.

For better understanding of this description it is needed to read the connecting and operating instructions of the KONTURflex because the QUATTRO CANopen is really a Modbus device with an internal Modbus to CANopen gateway.

Also if it is referred to "KONTURflex-Register", please see the attachment A of the instruction.

It is important to note that the described system must not be used as a safety related sensor.

Notes regarding important pieces of information are marked by the symbol  .

These connecting and operating instructions should be stored carefully. It should be available for the entire operating time of the KONTURflex.

The Leuze lumiflex GmbH + Co. KG is not liable for damages caused by improper use. Acquaintance with these instructions is an element of the knowledge required for proper use.

© Reprints and reproduction, in whole or in part, are permitted only with the explicit permission of

Leuze lumiflex GmbH + Co. KG  
Liebigstraße 4  
D-82256 Fürstfeldbruck, Germany  
Tel.: +49 8141 5350-0  
Fax.: +49 8141 5350-190  
E-Mail: lumiflex@leuze.de  
<http://www.leuze.com>

# Contents

1	Using the QUATTRO Software (PC).....	5
	Connections and switches.....	6
3	Object Dictionary.....	9
3.1	DS301: global Objects.....	9
3.2	DS301: PDO Parameter Objects.....	11
3.3	DS401: Digital Input Objects.....	12
3.4	DS401: Analog Input Objects.....	12
3.5	DS401: KONTURflex Objects Base Unit.....	13
3.6	DS401: KONTURflex Objects Sub Unit.....	13
4	Description of Object Dictionary.....	14
4.1	Index 0005.....	14
4.2	Index 0006.....	15
4.3	Index 0007.....	15
5	DS301: Global Objects.....	16
5.1	Index 1000 : Device Type.....	16
5.2	Index 1001 : Error Register.....	16
5.3	Index 1002 : Status Register.....	17
5.4	Index 1005 : COB-ID Sync.....	17
5.5	Index 1008 : Device Name.....	18
5.6	Index 1009 : Hardware Version.....	18
5.7	Index 100A : Software Version.....	18
5.8	Index 100B : Node-ID.....	19
5.9	Index 100C : Guard Time.....	19
5.10	Index 100D : Life Time Factor.....	20
5.11	Index 100E : COB-ID Guard.....	20
5.12	Index 1014 : COB-ID Emergency.....	20
5.13	Index 1015 : Inhibit Time Emergency.....	21
5.14	Index 1017 : Producer Heartbeat Time.....	21
5.15	Index 1018 : Identity Object.....	22
5.16	Index 1029 : Error Behaviour.....	23
5.17	Index 2000 : Device Manufacturer.....	24
5.18	Index 2101 : System Configuration.....	25
5.19	Index 2102 : Remapping Enabled Info.....	25
5.20	Index 2103 : Enabled Guarding Warning.....	25
5.21	Index 2105 : Internal API State Register.....	26
5.22	Index 2110 : CiA Test Entry.....	26
5.23	Index 2180 : CAN Restart Time.....	27
5.24	Index 5000 : Debug Register.....	28

<b>6</b>	<b>DS301: PDO Parameter Objects</b> .....	<b>28</b>
6.1	Communication Parameter Objects.....	28
6.2	PDO Mapping Objects.....	31
6.2.1	Receive PDOs.....	32
6.2.2	Transmit PDOs.....	33
<b>7</b>	<b>DS401: Digital Input Objects</b> .....	<b>34</b>
7.1	Index 6000 : Read Digital Input 8 Bit.....	34
7.2	Index 6005 : Global Interrupt Enable.....	35
7.3	Index 6006 : Interrupt Mask Any Change.....	35
<b>8</b>	<b>DS401: Analog Input Objects</b> .....	<b>36</b>
8.1	Index 6401 : Read Analog Input 16 Bit.....	36
8.2	Index 6421 : Analog Input Interrupt Trigger.....	40
8.3	Index 6423 : Analog Input Interrupt Enable.....	41
8.4	Index 6424/5/6 : Analog Input Interrupt Limits.....	42
<b>9</b>	<b>DS401: KONTURflex Base Unit Objects</b> .....	<b>44</b>
9.1	Index 4000 : KONTURflex Type Identification.....	44
9.2	Index 4002: Active Light Grid Ident.....	44
9.3	Index 4009 : KONTURflex Serial Number.....	45
9.4	Index 4014 : KONTURflex Production Date.....	45
9.5	Index 4018 : KONTURflex Hardware Version.....	46
9.6	Index 4019 : KONTURflex Software Version.....	46
9.7	Index 40C1 : KONTURflex Output Control.....	47
9.8	Index 40C4 : KONTURflex Base Unit State.....	48
9.9	Index 40C5 : Number of Active Beam Bytes.....	48
9.10	Index 4209 : Sub Unit Active Beam Bytes.....	49
9.11	Index 420A : Sub Unit Active Beams.....	49
9.12	Index 420B : Sub Unit Physical Beam Bytes.....	50
9.13	Index 420C : Sub Unit Physical Beams.....	51
9.14	Index 420D : Sub Unit Resolution.....	52
9.15	Index 420E : Sub Unit Range.....	52
9.16	Index 4213 : Sub Unit Scan Mode.....	53
9.17	Index 4218 : Sub Unit Config Register 0.....	54
9.18	Index 4219 : Sub Unit Config Register 1.....	55
9.19	Index 421A : Sub Unit Config Register 2.....	56
9.20	Index 421B : Sub Unit Config Register 3.....	57
9.21	Index 422C : Sub Unit State.....	58
9.22	Index 4234,5,6,7 : Sub Unit Measuring Field.....	59
<b>10</b>	<b>Emergency Messages</b> .....	<b>60</b>

## 1 Using the QUATTRO Software (PC)

The software on the PC for the KONTURflex configuration and diagnostic is also usable with the KONTURflex CANopen device.

The following things must be paid attention:

- The Firmware of the KONTURflex doesn't know anything about the internal connected CANopen gateway. So the QUATTRO Software is identifying the CANopen device as a Modbus Device.
- It is possible to do some diagnostics or to create test configurations for getting the programming values, but It makes no sense to do any configuration for the application by the QUATTRO software because all configuration is overwritten by the CANopen Master at connection establishment.
- Never change the Modbus address, it must be 1.
- While the QUATTRO Software is communicating with the device the CANopen communication is stopped. With the menu "Measurement Data/ view/stop" the CANopen Communication can be started again. If the QUATTRO Software is terminated in an irregularly way the device must be switched off to start the CANopen communication again.

## 2 Connections and switches

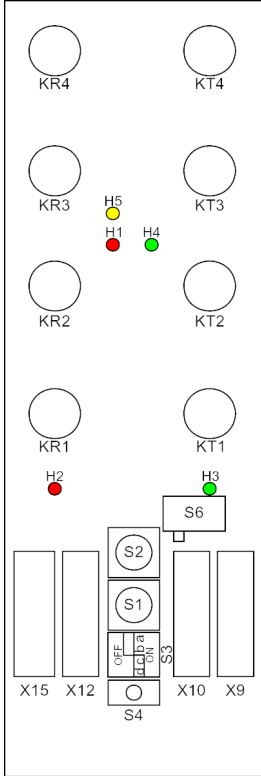

Fig. 2.1-1 QUATTRO-CANopen

Please note, that the QUATTRO CANopen schematic is different regarding the connecting and operating instructions of KONTURflex.

## Baud rate

The baud rate setting is done by the dip switch S3 abc

S3c	S3b	S3a	CAN-Baud Rate / Bus length		
off	off	off	1	Mbit/sec	25 m *1)
off	off	on	800	kbit/sec	50 m *1)
off	on	off	500	kbit/sec	100 m *2)
off	on	on	250	kbit/sec	250 m *2)
on	off	off	125	kbit/sec	500 m *3)
on	off	on	50	kbit/sec	1000 m *3)
on	on	off	20	kbit/sec	2500 m *3)
on	on	on	10	kbit/sec	5000 m *3)

\*1) Calculation without optocouplers.

For optocouplers bus length is reduced for about 4m per 10 nsec propagation delay of employed optocoupler type

\*2) Calculation with 40 nsec optocoupler propagation delay

\*3) Calculation with 100 nsec optocoupler propagation delay

The calculation of the bus length is based on a line propagation delay of 5 nsec/m.

## CAN Identifier

The CAN Identifier is set by the hex-switch S1 (low) and S2 (high).

All Identifiers from 1 to 127 are valid settings. Identifier 0 is used to load the ID from object 2100.

## Bus termination

The bus termination can be activated by dip switch S3d.

## Reset

A reset like powerup reset can be done by the pushbutton S4.

## Firmware update

By setting the switch S6 to the right and then powerup or reset the KONTURflex CANopen a Firmware update can be done.

## Power supply connection

### Plug X9 (grey):

PIN G	+24V
PIN F	GND
PIN J	PNP OUT
PIN H	free
PIN K	free

## RS232 connection

### Plug X10 (black):

PIN 6	free
PIN 7	free
PIN 8	GND
PIN 9	RS232 Transmitter
PIN 10	RS232 Receiver

## Can Bus Connection

### Plug X12 (green) and X15 (blue)

X12	X15	
PIN 1	PIN 1 (UL)	Gnd
PIN 2	PIN 2	CanL
PIN 3	PIN 3	shield
PIN 4	PIN 4	CanH
PIN 5	PIN 5	+24V (no connection to X9 PIN G)

Please refer at the description.

## Indication Leds

### Led H3(green)

- flashing while searching for light curtains after powerup, or if a light curtain is disconnected while in operation.
- off in normal operation.

### Led H2(red)

- off in normal operation
- on when switch S6 is set to the right position for a Firmware update

### Led H1(red) and H4(green)

- as defined in CANopen specification

### Led H5(yellow)

- flashing 10%on/90%off ready for operation
- flashing 50%on/50%off warning (bus status, non critical)
- flashing 80%on/20%off error

## 3 Object Dictionary

The KONTURflex CANopen implements a complex object dictionary for CANopen I/O devices.

 For detailed information about CANopen objects see additional brochure "Introduction to CANopen"

### 3.1 DS301: global Objects

For the objects tables all values are shown in hexadecimal way.  
For access type the following settings are valid:

ro            read only  
wo            write only  
rw            read and write access enabled

Index	Sub-Index	Name	Access
0005	-	Dummy 8	wo
0006	-	Dummy 16	wo
0007	-	Dummy 32	wo
1000	-	Device Type	ro
1001	-	Error Register	ro
1002	-	Manufacturer Status Register	ro
1005	-	COB-ID Sync Identifier Sync Object	rw
1008	-	Device Name *2)	ro
1009	-	Hardware Version *2)	ro

Index	Sub-Index	Name	Access
100A	-	Software Version *2)	ro
100B	-	Node Id *4)	-
100C	-	Guard Time	rw
100D	-	Life Time Factor	rw
100E	-	COB-ID Guard *4)	-
1014	-	COB ID Emergency	rw
1015	-	Inhibit Time Emergency	rw
1017	-	Producer Heartbeat Time	rw
1018	0	Identity Object	ro
	1	Vendor ID	ro
	2	Product Code	ro
	3	Revision Number	ro
	4	Serial Number	ro
1029	0	Error Behavior	ro
	1	In case of bus errors	rw
	2	In case of output errors	rw
2000	-	Device Manufacturer *3)	ro
2101	-	System Configuration	ro
2102	-	Remapping Enabled Info	ro
2103	-	Enable Guarding Warning	rw
2105	-	Internal Api State Register	ro
2110		CiA Conformance Test Entry	
	1	Conformance Test Entry 1	rw
2180	-	CAN Restart Time	rw
5000	-	Debug-Register	rw

**i** Notes:

- \*1) This object cannot be written to in operational device state. Only use this command in preoperational device state, otherwise the KONTURflex CANopen will answer requests with SDO abort telegrams.
- \*2) This objects show the chip type and version as visible strings.
- \*3) This Objects shows "Frenzel + Berg" as visible string data type.
- \*4) This object is not accessible for the application because of standard conforming reasons.

**i** All "Visible String" data type objects are restricted to a maximum of 20 characters. The data type entries Index 0005 to 0007 are implemented for compatibility reasons. They may be mapped to PDOs in order to define the appropriate space in the PDO.

For the read only objects following data is set:

Index	Sub.	Name	Value in Hex.
1000		Device Type	0007 0191 h
1018	0	Identity Object	04h
	1	Vendor ID	0000 0058 h
	2	Product Code	FF04 010A h
	3	Revision Number	0 .. 0xFFFFFFFF
	4	Serial Number	0
2101		System Configuration	Set according to the setting of the configuration input bits.

### 3.2 DS301: PDO Parameter Objects

Description of PDO Parameter objects:

These objects enable dynamic PDO mapping, variable identifier distribution for PDOs and setting of the transmission mode, inhibit and event times.

For the KONTURflex CANopen setting of all parameters may be done in the device state "operational" as well as in "preoperational" state.

Index	Sub-Index	Name	Access
1400	0	Receive PDO1 Communication Parameter	ro
	1	COB-ID	rw
	2	Transmission Type	rw
	3	Inhibit Time	rw
	4	Reserved	rw
	5	Event Time	rw
1600	0	Receive PDO1: Parameter mapping	rw
	1 to n	Mapped Object (max. 8 objects mappable)	rw
1800	0	Transmit PDO1 Communication Parameter	ro
	1	COB-ID	rw
	2	Transmission Type	rw
	3	Inhibit Time	rw
	4	Reserved	rw
	5	Event Time	rw

Index	Sub-Index	Name	Access
1801 ... 1805		Transmit PDO2 to TPDO6 Communication Parameter same as 1800.00 .. 1800.05	rw
1A00	0	Transmit PDO1 Parameter mapping	rw
	1 to n	Mapped Object (max. 8 objects mappable)	rw
1A01 ... 1A05		Transmit PDO2 to TPDO6 Parameter mapping Same as 1A00	rw

**i** The KONTURflex CANopen supports 1 receive and 6 transmit PDOs. All Objects for higher PDO numbers are not implemented.

### 3.3 DS401: Digital Input Objects

The digital input data represents the digital beam data of the KONTURflex.

Index	Sub-Index	Name	Access
6000	0 to n	Read digital input 8 bit (Digital beam data)	ro
6002	0 to n	Polarity input 8-bit	rw
6005		Global interrupt enable	rw
6006	0 to n	Interrupt mask: any change	rw

### 3.4 DS401: Analog Input Objects

The analog input objects represent the analog beam data of max 4 light grid elements.

Index	Sub-Index	Name	Access
6401	0 to n	Read Analog Input 16 Bit	ro
6421	0 to n	Analog Input Interrupt Trigger	rw
6423		Analog Input global Interrupt Enable	rw
6424	0 to n	Analog Input Upper Limit	rw
6425	0 to n	Analog Input Lower Limit	rw
6426	0 to n	Analog Input Interrupt Delta	rw

### 3.5 DS401: KONTURflex Objects Base Unit

Index	Sub-Index	Name	Access
4000	0	Type Identification (KONTURflex-Register 0x0000)	ro
4002	0	Active Light Grid Ident	ro
4009	0	Serial Number (KONTURflex-Register 0x0009)	ro
4014	0	Production Date (KONTURflex-Register 0x0014)	ro
4018	0	Hardware Version (KONTURflex-Register 0x0018)	ro
4019	0	Software Version (KONTURflex-Register 0x0019)	ro
40C1	0	Output Control (KONTURflex-Register 0x00C1)	rw
40C4	0	Base Unit State (KONTURflex-Register 0x00C4)	ro
40C5	0	Number of Active Beam Bytes	ro

### 3.6 DS401: KONTURflex Objects Sub Unit

Index	Sub-Index	Name	Access
4209	1 to 4	Sub Unit Number of Active Beam-Bytes (light grid 1 to 4)	ro
420A	1 to 4	Sub Unit Number of Active Beams (light grid 1 .. 4)	ro
420B	1 to 4	Sub Unit Number of Physical Beam-Bytes (light grid 1 to 4)	ro
420C	1 to 4	Sub Unit Number of Physical Beams (KONTURflex-Register 0x200C light grid 1 .. 4)	ro
420D	1 to 4	Sub Unit Resolution (KONTURflex-Register 0x200D light grid 1 .. 4)	rw
420E	1 to 4	Sub Unit Range (KONTURflex-Register 0x200E light grid 1 .. 4)	rw

Index	Sub-Index	Name	Access
4213	1 to 4	Sub Unit Scan Mode (KONTURflex-Register 0x2013 light grid 1 .. 4)	rw
4218	1 to 4	Sub Unit Configuration Reg0 (KONTURflex-Register 0x2018 light grid 1 .. 4)	rw
4219	1 to 4	Sub Unit Configuration Reg1 (KONTURflex-Register 0x2019 light grid 1 .. 4)	rw
421A	1 to 4	Sub Unit Configuration Reg2 (KONTURflex-Register 0x201A light grid 1 .. 4)	rw
421B	1 to 4	Sub Unit Configuration Reg3 (KONTURflex-Register 0x201B light grid 1 .. 4)	rw
422C	1 to 4	Sub Unit State (KONTURflex-Register 0x202C light grid 1 .. 4)	ro
4234	1 to 40	Sub Unit Measuring Field (KONTURflex-Register 0x2034 of light grid 1)	rw
4235	1 to 40	Sub Unit Measuring Field (KONTURflex-Register 0x2034 of light grid 2)	rw
4236	1 to 40	Sub Unit Measuring Field (KONTURflex-Register 0x2034 of light grid 3)	rw
4237	1 to 40	Sub Unit Measuring Field (KONTURflex-Register 0x2034 of light grid 4)	rw

## 4 Description of Object Dictionary

The following lists gives a short description of all dictionary entries.

### 4.1 Index 0005

This object is implemented to enable reservation of data space in PDOs by mapping dummy entries.

Index	0005
Name	Dummy 8
Description	
Data Type	Unsigned 8
Access modes	RO
PDO Mapping	Yes
Value Range	-
Default Value	0

#### 4.2 Index 0006

This object is implemented to enable reservation of data space in PDOs by mapping dummy entries.

Index	0006
Name	Dummy 16
Description	-
Data Type	Unsigned 16
Access modes	RO
PDO Mapping	Yes
Value Range	-
Default Value	0

#### 4.3 Index 0007

This object is implemented to enable reservation of data space in PDOs by mapping dummy entries.

Index	0007
Name	Dummy 32
Description	-
Data Type	Unsigned 32
Access modes	RO
PDO Mapping	Yes
Value Range	-
Default Value	0

## 5 DS301: Global Objects

### 5.1 Index 1000 : Device Type

Description of the device type. The Object gives the CiA device profile number and additionally the functionality of the device.

Index	1000h	
Name	Device Type	
Description	-	
Data Type	Unsigned 32	
Access modes	RO	
PDO Mapping	No	
Value Range	-	
Default Value	Operation Mode	Value of Index
	Mode 0	0005 0191 h

### 5.2 Index 1001 : Error Register

This object holds an error of the device.

Index	1001h	
Name	Error Register	
Description	-	
Data Type	Unsigned 8	
Access modes	RO	
PDO Mapping	Yes	
Value Range	-	
Default Value	-	

The error register has the following structure

Bit	Meaning
0	Generic error. This bit is set, if any error is active
1	0
2	0
3	0
4	CAN bus or communication error
5	0
6	0
7	Device Error

### 5.3 Index 1002 : Status Register

This object gives additional information for the device

This register shows the emergency coding of the device. See chapter Emergency Messages for detailed information.

Index	1002h
Name	Status Register
Description	-
Data Type	Unsigned 32
Access modes	RO
PDO Mapping	Yes
Value Range	-
Default Value	-

### 5.4 Index 1005 : COB-ID Sync

Identifier of Can Object for the Synchronisation message. The KONTURflex CANopen may only operate in Sync consumer mode. Generating of Sync messages is not possible. Therefore the Identifier for the Sync message can only be set to the value range 1 .. 7FFh.

Index	1005h
Name	COB-ID Sync
Description	-
Data Type	Unsigned 32
Access modes	RW
PDO Mapping	No
Value Range	1 .. 7FFh
Default Value	80h

### 5.5 Index 1008 : Device Name

This object shows the name of the device as visible string.

Index	1008h
Name	Device Name
Description	-
Data Type	Visible String
Access modes	RO
PDO Mapping	No
Value Range	The maximum string length is 20 characters
Default Value	"CO401Leuze01"

### 5.6 Index 1009 : Hardware Version

This object shows the hardware version as visible string. The output format is compatible to the format of the chip.

Index	1009h
Name	Hardware Version
Description	-
Data Type	Visible String
Access modes	RO
PDO Mapping	No
Value Range	The maximum string length is 20 characters
Default Value	-

### 5.7 Index 100A : Software Version

This object shows the software version as visible string.

Index	100Ah
Name	Software Version
Description	-
Data Type	Visible String
Access modes	RO
PDO Mapping	No
Value Range	The maximum string length is 20 characters
Default Value	-

## 5.8 Index 100B : Node-ID

This object keeps the actual node Id. The Object is not represented in the object dictionary because of standard conforming reasons.

Index	100Bh
Name	Node ID
Description	-
Data Type	Unsigned 8
Access modes	Not accessible
PDO Mapping	No
Value Range	1 to 127
Default Value	See below

## 5.9 Index 100C : Guard Time

The objects at index 100Ch (Guard Time in milliseconds) and 100Dh (Life Time Factor) are used to implement the life guarding protocol. The Guard Time multiplied with the Life Time Factor gives the Life Time in milliseconds.

It is 0 (zero) if not used.

Index	100Ch
Name	Guard Time
Description	-
Data Type	Unsigned 16
Access modes	RW
PDO Mapping	No
Value Range	
Default Value	0

### 5.10 Index 100D : Life Time Factor

The objects at index 100Ch (Guard Time in milliseconds) and 100Dh (Life Time Factor) are used to implement the life guarding protocol. The Guard Time multiplied with the Life Time Factor gives the Life Time in milliseconds.

It is 0 (zero) if not used.

Index	100Dh
Name	Life Time Factor
Description	-
Data Type	Unsigned 8
Access modes	RW
PDO Mapping	No
Value Range	
Default Value	0

### 5.11 Index 100E : COB-ID Guard

Identifier of Can Object for the Node Guarding protocol. The Object is not represented in the object dictionary because of standard conforming reasons.

Index	100Eh
Name	COB-ID Guard
Description	-
Data Type	Unsigned 32
Access modes	-
PDO Mapping	No
Value Range	-
Default Value	700h + Node-ID

### 5.12 Index 1014 : COB-ID Emergency

Identifier of Can Object for the emergency messages.

Index	1014h
Name	COB-ID Emergency
Description	-
Data Type	Unsigned 32
Access modes	RW
PDO Mapping	No
Value Range	-
Default Value	80h + Node-ID

### 5.13 Index 1015 : Inhibit Time Emergency

Inhibit Time for emergency messages. If the Inhibit Time is set to 0, inhibit delay is disabled. The Inhibit Time is a multiple of 100usec, but the KONTURflex CANopen offers a maximum resolution of 1 millisecond.

Index	1015h
Name	Inhibit Time Emergency
Description	-
Data Type	Unsigned 16
Access modes	RW
PDO Mapping	No
Value Range	-
Default Value	0

### 5.14 Index 1017 : Producer Heartbeat Time

The producer heartbeat time defines the cycle time of the heartbeat. The producer heartbeat time is 0 if it not used. The time has to be a multiple of 1ms.

Index	1017h
Name	Producer Heartbeat Time
Description	-
Data Type	Unsigned 16
Access modes	RW
PDO Mapping	No
Value Range	-
Default Value	0

**i** Note: Either Heartbeat or node guarding may be allowed at the same time. Do not use both protocols at the same time.

### 5.15 Index 1018 : Identity Object

The object at index 1018h keeps general information about the device and the manufacturer frenzel + berg elektronik. It cannot be modified.

Index	1018h
Name	Identity Object
Description	-
Data Type	Structure

Index	1018h Sub index 0
Name	Largest Sub index supported
Description	-
Data Type	Unsigned char
Access modes	RO
PDO Mapping	No
Value Range	-
Default Value	4

Index	1018h Sub index 1
Name	Vendor ID
Description	Registration Code of frenzel + berg elektronik at the CiA
Data Type	Unsigned 32
Access modes	RO
PDO Mapping	No
Value Range	-
Default Value	58h

Index	1018h Sub index 2
Name	Product Code
Description	Internal Product Code for CO401LEUZE01 at frenzel + berg elektronik
Data Type	Unsigned 32
Access modes	RO
PDO Mapping	No
Value Range	-
Default Value	FF40 100A h

Index	1018h Sub index 3
Name	Revision Code
Description	
Data Type	Unsigned 32
Access modes	RO
PDO Mapping	No
Value Range	-
Default Value	Revision of the device

Index	1018h Sub index 4
Name	Serial Number
Description	
Data Type	Unsigned 32
Access modes	RO
PDO Mapping	No
Value Range	-
Default Value	0

### 5.16 Index 1029 : Error Behaviour

With object 1029 the CANopen chip can be configured to enter alternatively the preoperational or the stopped state or remain in the current state in case of a device failure. Device failures shall include the following communication errors:

Bus-off conditions of the CAN interface, Life guarding error, Serious device errors also can be caused by device internal failures.

Index	1029h
Name	Error Behaviour Object
Description	-
Data Type	Structure

Index	1029h Sub index 0
Name	Largest Sub index supported
Description	-
Data Type	Unsigned char
Access modes	RO
PDO Mapping	No
Value Range	-
Default Value	2

Index	1029h Sub index 1
Name	Communication Error
Description	NMT state change in case of communication error
Data Type	Unsigned 8
Access modes	RW
PDO Mapping	No
Value Range	-
Default Value	00h

Index	1029h Sub index 2
Name	Application Error
Description	reserved
Data Type	Unsigned 8
Access modes	RW
PDO Mapping	No
Value Range	-
Default Value	00h

The value of the Error Classes is as follows:

0 = pre-operational

(only if current state is operational)

1 = no state change

2 = stopped

3 .. 127 = reserved

### 5.17 Index 2000 : Device Manufacturer

This object shows "Frenzel + Berg" as visible string. If OEMs do not want to give access to this entry, it may be removed from the EDS (electronic data sheet).

Index	2000h
Name	Device Manufacturer
Description	-
Data Type	Visible String
Access modes	RO
PDO Mapping	No
Value Range	The maximum string length is 20 characters
Default Value	"FRENZEL + BERG"

### 5.18 Index 2101 : System Configuration

This object returns the operation mode of the CO401LEUZE01. It represents the inverted Setting of the configuration input bits CFG0 to CFG5.

Index	2101h
Name	System Configuration
Description	-
Data Type	Unsigned 32
Access modes	RO
PDO Mapping	No
Value Range	-
Default Value	Depends on CFG0 to CFG5

### 5.19 Index 2102 : Remapping Enabled Info

This object informs the user whether the system configuration enables remapping of the PDOs.

A value of 0 means that remapping is disabled, all other values indicate that remapping of the PDOs is enabled.

Index	2102h
Name	Remapping Enabled Info
Description	-
Data Type	Unsigned 8
Access modes	RO
PDO Mapping	No
Value Range	-
Default Value	1

### 5.20 Index 2103 : Enabled Guarding Warning

This object enables/disables transmission of emergency messages in case of a node guarding warning.

The condition of a guarding warning is met, if the time between two node guarding frames increases the guarding time given in object 100C independent of the setting of the life time (object 100D). The node guarding warning does not cause any NMT state change or switching the output pins to the error state. It is implemented to give the CANopen master an early information that the guarding interval has already exceeded the predefined value.

The Guarding Warning is only generated if a valid life time is set. This requires that objects 100C and 100D must be set to a value unequal to zero.

0 : Guarding Warning is disabled

1 : Guarding Warning is enabled

Index	2103h
Name	Enable Guarding Warning
Description	-
Data Type	Unsigned 8
Access modes	RW
PDO Mapping	No
Value Range	-
Default Value	0

### 5.21 Index 2105 : Internal API State Register

This object shows the error state of the internal software. This object should always be 0. Otherwise an emergency is triggered.

Index	2105h
Name	Internal API state
Description	-
Data Type	Unsigned 32
Access modes	RO
PDO Mapping	No
Value Range	-
Default Value	0

### 5.22 Index 2110 : CiA Test Entry

This object is implemented due to a bug within the CANopen conformance test software. It avoids invalid error messages of the test software.

The test entry does not have any functional behaviour.

Index	2110h
Name	CiA Test Entry
Description	-
Data Type	Structure

Index	2110h Sub index 0
Name	Largest Sub index supported
Description	-
Data Type	Unsigned char
Access modes	RO
PDO Mapping	No
Value Range	-
Default Value	0x01

Index	2110h Sub index 1
Name	Test Entry 1
Description	-
Data Type	Unsigned 16
Access modes	RW
PDO Mapping	No
Value Range	100 .. 1000
Default Value	500

### 5.23 Index 2180 : CAN Restart Time

This object gives the restart time out for the CAN communication layer in case of bus off errors in milliseconds.

If the restart time is set to 0 automatic restart of the device in case of bus off is prohibited.

Index	2180h
Name	CAN Restart Time
Description	-
Data Type	Unsigned 16
Access modes	RW
PDO Mapping	No
Value Range	0 .. 50000
Default Value	1000 (restart after one second)

## 5.24 Index 5000 : Debug Register

This object is for factory test purposes and must not be used by the application.

Index	5000h
Name	Debug Register
Description	-
Data Type	Unsigned 32
Access modes	RW
PDO Mapping	No
Value Range	
Default Value	

## 6 DS301: PDO Parameter Objects

### 6.1 Communication Parameter Objects

The following table shows the communication parameter objects for Index 140x (Receive PDOs) and Index 180x (Transmit PDOs). The tables show Index 1400 as an example for all PDOs

Description of transmission type:

Type	PDO transmission				
	cyclic	acyclic	Sync related	Async.	Only on remote
0		X	X		
1-240	X		X		
241-251	Reserved				
252			X		X
253				X	X
254				X	
255				X	

Synchronous (transmission types 0-240 and 252) means that the transmission of the PDO shall be related to the SYNC object. Asynchronous means that the transmission of the PDO is not related to the SYNC object.

A transmission type of zero means that the message shall be transmitted synchronously with the SYNC object but not periodically but only in case of data change.

A value between 1 and 240 means that the PDO is transferred synchronously and cyclically, the transmission type indicating the number of SYNC signals, which are necessary to trigger PDO transmissions or receptions.

The transmission types 252 and 253 mean that the PDO is only transmitted on reception of a remote frame. At transmission type 252, the data is updated (but not sent) immediately after reception of the SYNC object. At transmission type 253 the data is updated at the reception of the remote frame. These values are only possible for transmit PDOs.

Transmission type 255 means, the application event is defined in the device profile. For receive PDOs the reception of a PDO will update the mapped data (normally the analog or digital outputs).

The PDO communication parameter objects have the same structure for all PDOs. The following objects are used.

Sub-index 4h is reserved.

Index	PDO
1400h	Receive PDO1
1800h	Transmit PDO1
1801h	Transmit PDO2
1802h	Transmit PDO3
1803h	Transmit PDO4
1804h	Transmit PDO5
1805h	Transmit PDO6

Index	14xxh / 18xxh
Name	Receive / Transmit PDOx Communication Parameters
Description	-
Data Type	Structure

Index	14xxh / 18xxh Sub index 0
Name	Largest Sub index supported
Description	-
Data Type	Unsigned 8
Access modes	RO
PDO Mapping	No
Value Range	-
Default Value	2 / 5

Index	14xxh / 18xxh Sub index 1	
Name	COB-ID	
Description	Identifier for CAN-Object for PDO	
Data Type	Unsigned 32	
Access modes	RW	
PDO Mapping	No	
Value Range	-	
Default Value	1400.01	Node-Id + 80000200h
	1800.01	Node-Id + 180h
	1801.01	Node-Id + 280h
	1802.01	Node-Id + 380h
	1803.01	Node-Id + 480h
	1804.01	Node-Id + 80000000h
	1805.01	Node-Id + 80000000h

An Identifier of 8xxxxxxh means, that this PDO is disabled by default and must be enabled from the CANopen master by assigning a valid PDO ID.

The transmission type (sub-index 2) defines the mode for transmission / reception of the PDO. See table for detailed description of this entry.

Index	14xxh / 18xxh Sub index 2	
Name	Transmission Type	
Description	-	
Data Type	Unsigned 8	
Access modes	RW	
PDO Mapping	No	
Value Range	-	
Default Value	0FFh	

Sub-index 3h contains the inhibit time. This time is a minimum interval for PDO transmission. The value is defined as multiple of 100ms.

Index	18xxh Sub index 3	
Name	Inhibit Time	
Description	-	
Data Type	Unsigned 16	
Access modes	RW	
PDO Mapping	No	
Value Range	-	
Default Value	0	

Index	18xxh Sub index 4
Name	Reserved
Description	-
Data Type	-
Access modes	-
PDO Mapping	No
Value Range	-
Default Value	-

In mode 254/255 additionally an event time can be used for TPDO. If an event timer exists for a TPDO (value not equal to 0) the elapsed timer is considered to be an event. The event time is a multiple of 1 ms. This event will cause the transmission of this TPDO in addition to otherwise defined events.

Index	18xxh Sub index 5
Name	Event Time
Description	-
Data Type	Unsigned 16
Access modes	RW
PDO Mapping	No
Value Range	-
Default Value	0

## 6.2 PDO Mapping Objects

The following table shows the PDO Mapping Objects. The principle of PDO mapping is the same for all PDOs. The PDO Mapping table is the cross reference between the Object dictionary entries (for example the data of an digital output byte) and the data field inside an PDO data field (position in the data field of a CAN message for PDO transfer).

Sub index 0 determines the valid number of objects that have been mapped. The CANopen controller allows a maximum of 8 mapped objects for each PDO. For changing the PDO mapping first sub index 0 must be set to 0 (mapping is deactivated). Then the objects can be remapped. When a new object is mapped by writing a sub index between 1 and 8, the device may check whether the object specified by index /sub index exists. If the object does not exist or the object cannot be mapped, the SDO transfer will be aborted.

Sub indexes 1 to 8 keep the pointers of the mapped objects as unsigned 32 values. The value is 0 if there is no mapped object. The structure for these pointers is as follows.

MSB		LSB	
Byte3	Byte2	Byte1	Byte0
Mapped index		Sub index	Length

Mapped Index and Sub index together are the Pointer to the Object dictionary data to be mapped at this location.

Length gives the length of the mapped object in bits.

Index	160xh / 1A0xh
Name	Receive / Transmit PDO Mapping Parameters
Description	-
Data Type	Array

Index	160xh / 1A0xh Sub index 0
Name	Largest Sub index supported
Description	Number of mapped objects
Data Type	Unsigned 8
Access modes	RW
PDO Mapping	No
Value Range	-
Default Value	See table below

Index	160xh / 1A0xh Sub index 1 to 8
Name	Mapped object
Description	
Data Type	Unsigned 32
Access modes	RW
PDO Mapping	No
Value Range	-
Default Value	See table below

### 6.2.1 Receive PDOs

The CANopen chip CO401Leuze01 uses the following default mapping entries for receive PDO mapping:

Index	Entry	Explanation
Receive-PDO1		
1600.00	0	RPDO1: 0 mapped objects
Receive-PDO2		
1601.00	0	RPDO2: 0 mapped objects

## 6.2.2 Transmit PDOs

The CANopen chip CO401Leuze01 uses the following default mapping entries for transmit PDO mapping:

Index	Entry	Explanation
<b>Transmit-PDO1</b>		
1A00.00	8	TPDO1: 8 mapped objects
1A00.01	60000108h	Digital Input Byte0
1A00.02	60000208h	Digital Input Byte1
1A00.03	60000308h	Digital Input Byte2
1A00.04	60000408h	Digital Input Byte3
1A00.05	60000508h	Digital Input Byte4
1A00.06	60000608h	Digital Input Byte5
1A00.07	60000708h	Digital Input Byte6
1A00.08	60000808h	Digital Input Byte7
<b>Transmit -PDO2</b>		
1A01.00	4	TPDO2: 4 mapped objects
1A01.01	64010110h	Analog Input Integer 0
1A01.02	64010210h	Analog Input Integer 1
1A01.03	64010310h	Analog Input Integer 2
1A01.04	64010410h	Analog Input Integer 3
<b>Transmit -PDO3</b>		
1A02.00	4	TPDO3: 4 mapped objects
1A02.01	64010510h	Analog Input Integer 4
1A02.02	64010610h	Analog Input Integer 5
1A02.03	64010710h	Analog Input Integer 6
1A02.04	64010810h	Analog Input Integer 7
<b>Transmit -PDO4</b>		
1A03.00	4	TPDO4: 4 mapped objects
1A03.01	64010910h	Analog Input Integer 8
1A03.02	64010A10h	Analog Input Integer 9
1A03.03	64010B10h	Analog Input Integer 10
1A03.04	64010C10h	Analog Input Integer 11
<b>Transmit -PDO5</b>		
1A04.00	0	TPDO5: 0 mapped objects
<b>Transmit -PDO6</b>		
1A05.00	0	TPDO6: 0 mapped objects

## 7 DS401: Digital Input Objects

The following objects are describing the functionality of the digital input lines of the KONTURflex CANopen. The KONTURflex CANopen supports 8 bit access to the digital inputs. The number of digital beam data is forced to 40h. This is the maximum available within a KONTURflex system.

### 7.1 Index 6000 : Read Digital Input 8 Bit

This object represents the digital beam data of all connected light grids.

Index	6000h
Name	Digital Input 8 Bit
Description	-
Data Type	Array

Index	Sub index 0
Name	Nr of Subobjects
Description	
Data Type	Unsigned 8
Access modes	RO
PDO Mapping	No
Value Range	-
Default Value	40h

Index	Sub index 1 to 40h of input bytes
Name	Light Grid 1 to 4 Digital Beam Data 8 Bit
Description	
Data Type	Unsigned 8
Access modes	RO
PDO Mapping	Yes
Value Range	-
Default Value	-

If more than one beam is logically connected with a logic AND or a logic OR function, object 6000 does not longer show the single beam information but always the connected beam data.

### 7.2 Index 6005 : Global Interrupt Enable

This object enables or disables globally the interrupt behaviour without changing the interrupt masks.

In event-driven mode the device transmits the input values depending on the interrupt masks in objects 6006h, 6007h, and 6008h and the PDO transmission type.

TRUE (1)= global interrupt enabled

FALSE (0)= global interrupt disabled

Index	6005h
Name	Global Interrupt Enable
Description	-
Data Type	Boolean
Access modes	RW
PDO Mapping	No
Value Range	-
Default Value	TRUE

### 7.3 Index 6006 : Interrupt Mask Any Change

This object determines, which input lines shall activate an interrupt by any change of the input line. Both negative and positive edge will cause an interrupt, if enabled.

An interrupt will cause a PDO transmission in case of event driven transmission mode.

1 = interrupt enabled

0 = interrupt disabled

Index	6006h
Name	Interrupt Mask any change
Description	-
Data Type	Array

Index	Sub index 0
Name	Nr of Subobjects
Description	
Data Type	Unsigned 8
Access modes	RO
PDO Mapping	No
Value Range	-
Default Value	Number of digital input bytes

Index	Sub index 1 to Nr of input bytes
Name	Interrupt Mask any change
Description	
Data Type	Unsigned 8
Access modes	RW
PDO Mapping	No
Value Range	-
Default Value	0FFh (interrupt enabled)

## 8 DS401: Analog Input Objects

The following objects are describing the functionality of the analog input lines of the KONTURflex CANopen.

The number of analog input bytes depends on the selected operation mode.

### 8.1 Index 6401 : Read Analog Input 16 Bit

Object 6401, represents the value of the analog channels. The objects represent the KONTURflex beam data information field. See table.

Index	6401h
Name	Read Analog Input
Description	-
Data Type	Array

Index	Sub index 0
Name	
Description	Nr of Subobjects
Data Type	Unsigned 8
Access modes	RO
PDO Mapping	NO
Value Range	-
Default Value	48h Number of analog input channels

Index	Sub index 1 to Nr of input lines
Name	Read Analog Input
Description	
Data Type	Signed 16
Access modes	RO
PDO Mapping	YES
Value Range	-
Default Value	-

Analog beam information for the light grids 1 to 4 are represented in sub objects 1 to 48h of object 6401. For analog PDO trigger conditions sub objects 1 to 48h of trigger condition objects 6424, 6425 and 6426 are associated with the same sub index of beam information data (object 6401).

The subobjects are associated to the light grids:

LG1	Light grid 1
LG2	Light grid 2
LG3	Light grid 3
LG4	Light grid 4

Index.Sub	KONTURflex Data
<b>TU</b>	<b>Lowest interrupted beam (KONTURflex-Register 0x214F)</b>
0x6401.01	Lowest interrupted beam : LG1
0x6401.02	Lowest interrupted beam : LG2
0x6401.03	Lowest interrupted beam : LG3
0x6401.04	Lowest interrupted beam : LG4
<b>HU</b>	<b>Highest interrupted beam (KONTURflex-Register 0x2150)</b>
0x6401.05	Highest interrupted beam : LG1
0x6401.06	Highest interrupted beam : LG2
0x6401.07	Highest interrupted beam : LG3
0x6401.08	Highest interrupted beam : LG4
<b>ZU</b>	<b>Number of interrupted beams (KONTURflex-Register 0x2151)</b>
0x6401.09	Nr. of interrupted beams : LG1
0x6401.0A	Nr. of interrupted beams : LG2
0x6401.0B	Nr. of interrupted beams : LG3
0x6401.0C	Nr. of interrupted beams : LG4

Index.Sub	KONTURflex Data
<b>TNU Lowest not interrupted beam (KONTURflex-Register 0x2152)</b>	
0x6401.0D	Lowest not interrupted beam : LG1
0x6401.0E	Lowest not interrupted beam : LG2
0x6401.0F	Lowest not interrupted beam : LG3
0x6401.10	Lowest not interrupted beam : LG4
<b>HNU Highest not interrupted beam (KONTURflex-Register 0x2153)</b>	
0x6401.11	Highest not interrupted beam : LG1
0x6401.12	Highest not interrupted beam : LG2
0x6401.13	Highest not interrupted beam : LG3
0x6401.14	Highest not interrupted beam : LG4
<b>ZNU Number of not interrupted beams (KONTURflex-Register 0x2154)</b>	
0x6401.15	Nr. of not interrupted beams : LG1
0x6401.16	Nr. of not interrupted beams : LG2
0x6401.17	Nr. of not interrupted beams : LG3
0x6401.18	Nr. of not interrupted beams : LG4

Index.Sub	KONTURflex Data
<b>TUmin Lowest interrupted beam min (KONTURflex-Register 0x2155)</b>	
0x6401.19	Lowest interr. beam min : LG1
0x6401.1A	Lowest interr. beam min : LG2
0x6401.1B	Lowest interr. beam min : LG3
0x6401.1C	Lowest interr. beam min : LG4
<b>HUmin Highest interrupted beam min (KONTURflex-Register 0x2156)</b>	
0x6401.1D	Highest interr. beam min : LG1
0x6401.1E	Highest interr. beam min : LG2
0x6401.1F	Highest interr. beam min : LG3
0x6401.20	Highest interr. beam min : LG4
<b>ZUmin Number of interrupted beams min (KONTURflex-Register 0x2157)</b>	
0x6401.21	Nr. of interr. beams min : LG1
0x6401.22	Nr. of interr. beams min : LG2
0x6401.23	Nr. of interr. beams min : LG3
0x6401.24	Nr. of interr. beams min : LG4

<b>Index.Sub</b>	<b>KONTURflex Data</b>
<b>TNUmin Lowest not interrupted beam min (KONTURflex-Register 0x2158)</b>	
0x6401.25	Lowest not int. beam min : LG1
0x6401.26	Lowest not int. beam min : LG2
0x6401.27	Lowest not int. beam min : LG3
0x6401.28	Lowest not int. beam min : LG4
<b>HNUmin Highest not interrupted beam min (KONTURflex-Register 0x2159)</b>	
0x6401.29	Highest not int. beam min: LG1
0x6401.2A	Highest not int. beam min: LG2
0x6401.2B	Highest not int. beam min: LG3
0x6401.2C	Highest not int. beam min: LG4
<b>ZNUmin Number of not interrupted beams min (KONTURflex-Register 0x215A)</b>	
0x6401.2D	Nr. of not int. beams min : LG1
0x6401.2E	Nr. of not int. beams min : LG2
0x6401.2F	Nr. of not int. beams min : LG3
0x6401.30	Nr. of not int. beams min : LG4

<b>Index.Sub</b>	<b>KONTURflex Data</b>
<b>TUmax Lowest interrupted beam max (KONTURflex-Register 0x215B)</b>	
0x6401.31	Lowest interr. beam max : LG1
0x6401.32	Lowest interr. beam max : LG2
0x6401.33	Lowest interr. beam max : LG3
0x6401.34	Lowest interr. beam max : LG4
<b>HUmax Highest interrupted beam max (KONTURflex-Register 0x215C)</b>	
0x6401.35	Highest interr. beam max : LG1
0x6401.36	Highest interr. beam max : LG2
0x6401.37	Highest interr. beam max : LG3
0x6401.38	Highest interr. beam max : LG4
<b>ZUmax Number of interrupted beams max (KONTURflex-Register 0x215D)</b>	
0x6401.39	Nr. of interr. beams max : LG1
0x6401.3A	Nr. of interr. beams max : LG2
0x6401.3B	Nr. of interr. beams max : LG3
0x6401.3C	Nr. of interr. beams max : LG4

Index.Sub	KONTURflex Data
<b>TNUmax                    Lowest not interrupted beam max (KONTURflex-Register 0x215E)</b>	
0x6401.3D	Lowest not int. beam max: LG1
0x6401.3E	Lowest not int. beam max: LG2
0x6401.3F	Lowest not int. beam max: LG3
0x6401.40	Lowest not int. beam max: LG4
<b>HNUmax                    Highest not interrupted beam max (KONTURflex-Register 0x215F)</b>	
0x6401.41	Highest not int. beam max:LG1
0x6401.42	Highest not int. beam max:LG2
0x6401.43	Highest not int. beam max:LG3
0x6401.44	Highest not int. beam max:LG4
<b>ZNUMax                    Number of not interrupted beams max (KONTURflex-Register 0x2160)</b>	
0x6401.45	Nr. of not int. beams max: LG1
0x6401.46	Nr. of not int. beams max: LG2
0x6401.47	Nr. of not int. beams max: LG3
0x6401.48	Nr. of not int. beams max: LG4

## 8.2 Index 6421 : Analog Input Interrupt Trigger

Object 6421 selects the event that shall cause a transmission interrupt for the selected analog channel. See also description of objects 6424, 6425 and 6426 for further information how to cause a PDO transmission.

There is one Sub index for each channel to enable individual setting according to application requirements.

### Table of possible Trigger Conditions:

Bit Nr	Interrupt Trigger Selection
0	Input voltage greater than Upper Limit
1	Input voltage less than Lower Limit
2	Input changed by more than Delta
3	Input reduced more than Negative Delta
4	Input increased more than Positive Delta
3 to 7	Reserved (must be forced to zero)

Index	6421h
Name	Analog Input Interrupt Trigger
Description	-
Data Type	Array

Index	Sub index 0
Name	
Description	Nr of Subobjects
Data Type	Unsigned 8
Access modes	RO
PDO Mapping	NO
Value Range	-
Default Value	48h Nr of analog input channels

Index	Sub index 1 to Nr of input lines
Name	Analog Input Interrupt Trigger
Description	Selects trigger condition
Data Type	Unsigned 8 (See Table of Trigger Conditions)
Access modes	RW
PDO Mapping	No
Value Range	-
Default Value	7

### 8.3 Index 6423 : Analog Input Interrupt Enable

This object enables or disables globally the interrupt behaviour without changing the interrupt masks.

The interrupt is disabled by default, in order to avoid transmission of analog input values.

TRUE (1)= global interrupt enabled

FALSE (0)= global interrupt disabled

Index	6423h
Name	Analog Input Interrupt Enable
Description	-
Data Type	Boolean
Access modes	RW
PDO Mapping	No
Value Range	-
Default Value	FALSE

### 8.4 Index 6424/5/6 : Analog Input Interrupt Limits

These objects give the Limit for generation of interrupts. All objects have the same structure.

The function of the interrupt limit is only enabled, if the corresponding bit of object 6421 is set.

All values of limit parameters are signed 32. So the user must take care not to exceed the range of the input data objects.

Flowchart for generating a PDO trigger condition

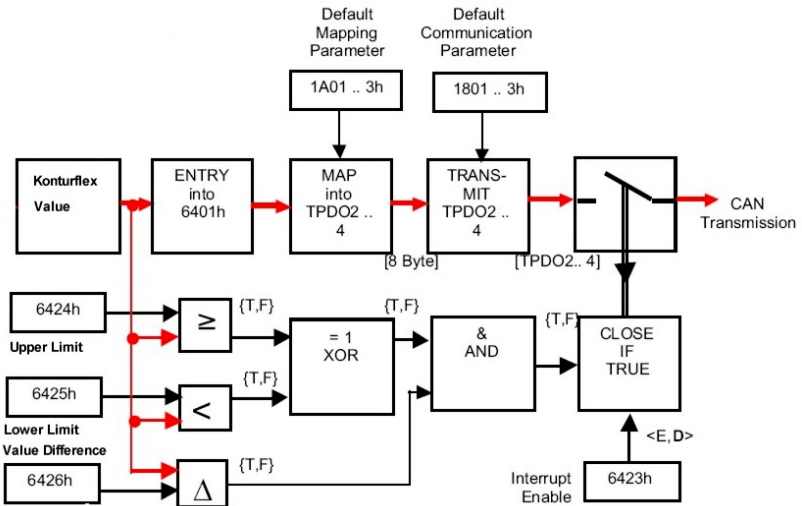

**Table of Limit Function**

Object	Object Name and Function
6424	Analog Input Upper Limit Generate interrupt if input voltage is greater than or equal to Upper Limit (6424)
6425	Analog Input Lower Limit Generate interrupt if input voltage is less than Lower Limit (6425)
6426	Analog Input Interrupt Delta Generate interrupt if input voltage changed by more than Interrupt Delta

<b>Index</b>	<b>6424 / 6425 / 6426</b>
Name	See table above
Description	-
Data Type	Array

<b>Index</b>	<b>Sub index 0</b>
Name	
Description	Nr of Subobjects
Data Type	Unsigned 8
Access modes	RO
PDO Mapping	NO
Value Range	-
Default Value	Number of analog input channels

<b>Index</b>	<b>Sub index 1 to Nr of input lines</b>
Name	See table above
Description	
Data Type	Integer 32
Access modes	RW
PDO Mapping	No
Value Range	-
Default Value	0

## 9 DS401: KONTURflex Base Unit Objects

The following objects are describing the functionality of the KONTURflex base unit.

### 9.1 Index 4000 : KONTURflex Type Identification

Object 4000 shows the type of the KONTURflex system.

Index	4000h
Name	KONTURflex Type Identification
Description	This object is forced to 0x32 in order to identify the KONTURflex system. This object is directly read from the KONTURflex-Register 0x0000.
Data Type	Unsigned 16
Access modes	RO
PDO Mapping	NO
Value Range	-
Default Value	0x32

### 9.2 Index 4002: Active Light Grid Ident

Object 4002 shows the active state of connected light grids.

Index	4002h
Name	Active Light Grid Ident
Description	An active light grid is marked with a binary 1 at the associated bit position within this object. Bit 0 light grid 1 Bit 1 light grid 2 Bit 2 light grid 3 Bit 3 light grid 4
Data Type	Unsigned 8
Access modes	RO
PDO Mapping	NO
Value Range	-
Default Value	

### 9.3 Index 4009 : KONTURflex Serial Number

This object shows the name of the device as visible string.

Index	4009h
Name	KONTURflex Serial Number
Description	This object is directly read from the KONTURflex-Register 0x0009
Data Type	Visible String
Access modes	RO
PDO Mapping	No
Value Range	The maximum string length is 10 characters
Default Value	

### 9.4 Index 4014 : KONTURflex Production Date

This object shows the production date of the KONTURflex system in visible string format.

Index	4014h
Name	KONTURflex Production Date
Description	This object shows the production date of the KONTURflex system. This object is directly read from the KONTURflex-Register 0x0014
Data Type	Visible String
Access modes	RO
PDO Mapping	No
Value Range	The maximum string length is 8 characters
Default Value	YYYYMMDD YYYY Year : 4 digits MM Month : 2 digits DD Day : 2 digits

### 9.5 Index 4018 : KONTURflex Hardware Version

This object shows the hardware version of the KONTURflex system in unsigned integer format.

Index	4018h
Name	KONTURflex Hardware Version
Description	This object shows the hardware version of the KONTURflex system. This object is directly read from the KONTURflex-Register 0x0018
Data Type	Unsigned 16
Access modes	RO
PDO Mapping	No
Value Range	-
Default Value	MSByte Main version LSByte Sub version

### 9.6 Index 4019 : KONTURflex Software Version

This object shows the software version of the KONTURflex system in unsigned integer format.

Index	4019h
Name	KONTURflex Software Version
Description	This object shows the software version of the KONTURflex system. This object is directly read from the KONTURflex-Register 0x0019
Data Type	Unsigned 16
Access modes	RO
PDO Mapping	No
Value Range	-
Default Value	MSByte Main version LSByte Sub version

## 9.7 Index 40C1 : KONTURflex Output Control

This object is used to configure the hardware output of the KONTURflex system.

Index	40C1h
Name	KONTURflex Output Control
Description	<p>The PNP output is switched to active mode if the selected conditions are active on the selected light grid module:</p> <p>Bit0 no beam detects object            Bit1 all beams detect object            Bit2 object path in the middle            Bit3 object path too high            Bit4 object path too low            Bit5 hole detected            Bit6,7 reserved</p> <p>The rest of the bits are used to setup the PNP output</p> <p>Bit8,9 light grid module number            Bit14 changes after every scan            Bit15 active polarity for PNP Output.</p> <p>1 : active high            0 : active low</p> <p>This object is directly exchanged with the KONTURflex-Register 0x00C1</p>
Data Type	Unsigned 16
Access modes	RW
PDO Mapping	No
Value Range	-
Default Value	1

### 9.8 Index 40C4 : KONTURflex Base Unit State

This object shows the state of the KONTURflex base unit.

Index	40C4h
Name	KONTURflex Base Unit State
Description	Bit0 Emergency Is set if any error detected. Bit1 PNP output is active Bit2 no light grid connected Bit4..15 Internal error. This object is directly read from the KONTURflex-Register 0x00C4
Data Type	Unsigned 16
Access modes	RO
PDO Mapping	YES
Value Range	-
Default Value	0

### 9.9 Index 40C5 : Number of Active Beam Bytes

This object shows the number of all active beam bytes for the complete KONTURflex system. For calculating the “Number of Active Beam Bytes” all light grid modules are added.

Note: Calculation of active beam bytes is only done directly after reset. This object cannot be used for monitoring the light grid modules.

Index	40C5h
Name	Number of Active Beam Bytes
Description	
Data Type	Unsigned 16
Access modes	RO
PDO Mapping	YES
Value Range	-
Default Value	0

### 9.10 Index 4209 : Sub Unit Active Beam Bytes

This object shows the number of bytes of active beams of the light grid modules. The number of active beams may differ from the number of physical beams, if more than one physical beams are connected together using object 4218h.

Index	4209h
Name	Sub Unit Active Beam Bytes
Description	-
Data Type	Array

Index	Sub index 0
Name	Max number of light grids
Description	Nr of Subobjects
Data Type	Unsigned 8
Access modes	RO
PDO Mapping	NO
Value Range	-
Default Value	4

Index	Sub index 1 to Nr of input lines
Name	Sub Unit Active Beam Bytes
Description	Number of active beam bytes within light grid module 1 .. 4.
Data Type	Unsigned 16
Access modes	RO
PDO Mapping	No
Value Range	-
Default Value	

### 9.11 Index 420A : Sub Unit Active Beams

This object shows the number of active beams of the light grid modules. The number of active beams may differ from the number of physical beams, if more than one physical beams are connected together using object 4218h.

Index	420Ah
Name	Sub Unit Active Beams
Description	-
Data Type	Array

Index	Sub index 0
Name	Max number of light grids
Description	Nr of Subobjects
Data Type	Unsigned 8
Access modes	RO
PDO Mapping	NO
Value Range	-
Default Value	4

Index	Sub index 1 to Nr of input lines
Name	Sub Unit Active Beams
Description	Number of active beams within light grid module 1 .. 4.
Data Type	Unsigned 16
Access modes	RO
PDO Mapping	No
Value Range	-
Default Value	

## 9.12 Index 420B : Sub Unit Physical Beam Bytes

This object shows the number of bytes of physical beams of the light grid modules. The number of physical beams gives the number of hardware light barriers within a light grid module.

Index	420Bh
Name	Sub Unit Physical Beam Bytes
Description	-
Data Type	Array

Index	Sub index 0
Name	Max number of light grids
Description	Nr of Subobjects
Data Type	Unsigned 8
Access modes	RO
PDO Mapping	NO
Value Range	-
Default Value	4

Index	Sub index 1 to Nr of input lines
Name	Sub Unit Physical Beam Bytes
Description	Number of physical beam bytes within light grid module 1 .. 4.
Data Type	Unsigned 16
Access modes	RO
PDO Mapping	No
Value Range	-
Default Value	

### 9.13 Index 420C : Sub Unit Physical Beams

This object shows the number of physical beams of the light grid modules. The number of physical beams gives the number of hardware light barriers within a light grid module.

Index	420Ch
Name	Sub Unit Physical Beams
Description	-
Data Type	Array

Index	Sub index 0
Name	Max number of light grids
Description	Nr of Subobjects
Data Type	Unsigned 8
Access modes	RO
PDO Mapping	NO
Value Range	-
Default Value	4

Index	Sub index 1 to Nr of input lines
Name	Sub Unit Physical Beams
Description	Number of physical beams within light grid module 1 .. 4.
Data Type	Unsigned 16
Access modes	RO
PDO Mapping	No
Value Range	-
Default Value	

### 9.14 Index 420D : Sub Unit Resolution

This object sets the resolution of the light grid modules. The object has no effect on the light grid modules.

Index	420Dh
Name	Sub Unit Resolution
Description	-
Data Type	Array

Index	Sub index 0
Name	Max number of light grids
Description	Nr of Subobjects
Data Type	Unsigned 8
Access modes	RW
PDO Mapping	NO
Value Range	-
Default Value	4

Index	Sub index 1 to Nr of input lines
Name	Sub Unit Resolution
Description	This object is directly exchanged with the KONTURflex-Register 0x200D
Data Type	Unsigned 16
Access modes	RW
PDO Mapping	No
Value Range	5, 10, 20, 40 mm / Degrees
Default Value	5

### 9.15 Index 420E : Sub Unit Range

This object sets the range of the light grid modules.

Index	420Eh
Name	Sub Unit Range
Description	-
Data Type	Array

Index	Sub index 0
Name	Max number of light grids
Description	Nr of Subobjects
Data Type	Unsigned 8
Access modes	RO
PDO Mapping	NO
Value Range	-
Default Value	4

Index	Sub index 1 to Nr of input lines
Name	Sub Unit Resolution
Description	This object is directly exchanged with the KONTURflex-Register 0x200E
Data Type	Unsigned 16
Access modes	RO
PDO Mapping	No
Value Range	0..5 0      5 – 30 cm 1      20 – 100 cm 2      50 – 150 cm 3      100 – 250 cm 4      200 – 350 cm 5      300 – 400 cm
Default Value	5

### 9.16 Index 4213 : Sub Unit Scan Mode

This object sets the scan mode of the light grid modules. Number of scans for integration.

Index	4213h
Name	Sub Unit Scan Mode
Description	-
Data Type	Array

<b>Index</b>	<b>Sub index 0</b>
Name	Max number of light grids
Description	Nr of Subobjects
Data Type	Unsigned 8
Access modes	RO
PDO Mapping	NO
Value Range	-
Default Value	4

<b>Index</b>	<b>Sub index 1 to Nr of input lines</b>
Name	Sub Unit Scan Mode
Description	This object is directly exchanged with the KONTURflex-Register 0x2013
Data Type	Unsigned 16
Access modes	RW
PDO Mapping	No
Value Range	1 .. 63
Default Value	1

### 9.17 Index 4218 : Sub Unit Config Register 0

This object enables connecting more than one physical beams to a logical beam.

<b>Index</b>	<b>4218h</b>
Name	Sub Unit Config Register 0
Description	-
Data Type	Array

<b>Index</b>	<b>Sub index 0</b>
Name	Max number of light grids
Description	Nr of Subobjects
Data Type	Unsigned 8
Access modes	RO
PDO Mapping	NO
Value Range	-
Default Value	4

Index	Sub index 1 to Nr of input lines
Name	Sub Unit Config Register 0
Description	This object is directly exchanged with the KONTURflex-Register 0x2018 Word 0
Data Type	Unsigned 16
Access modes	RW
PDO Mapping	No
Value Range	Bits 0..6 Group counter (1..127) Number of physical beams, to connect. Bit 15 Logical connection 0 : logical AND 1 : logical OR
Default Value	1

Connecting more than one physical beams to a logic beam using the group counter <> 0, affects the following objects: 40C5, 4209, 420A and the assignment of the active beams to object 600x.

If the user wants to connect more than one physical beams using this object must take care of the correct setup step sequence.

It is recommended to use the following order:

- 1) Setup object 4218 (group counters) for all sub units.
- 2) Map the requested digital beam data to the PDOs.
- 3) Start node.

### 9.18 Index 4219 : Sub Unit Config Register 1

This object sets the hold time for a scanning result.

Index	4219h
Name	Sub Unit Config Register 1
Description	-
Data Type	Array

<b>Index</b>	<b>Sub index 0</b>
Name	Max number of light grids
Description	Nr of Subobjects
Data Type	Unsigned 8
Access modes	RO
PDO Mapping	NO
Value Range	-
Default Value	4

<b>Index</b>	<b>Sub index 1 to Nr of input lines</b>
Name	Sub Unit Config Register 1
Description	This object is directly exchanged with the KONTURflex-Register 0x2018 Word 1
Data Type	Unsigned 16
Access modes	RW
PDO Mapping	No
Value Range	1 .. 255
Default Value	10

### 9.19 Index 421A : Sub Unit Config Register 2

This object sets the hole size for automatic hole detection within the KONTURflex system.

<b>Index</b>	<b>421Ah</b>
Name	Sub Unit Config Register 2
Description	-
Data Type	Array

<b>Index</b>	<b>Sub index 0</b>
Name	Max number of light grids
Description	Nr of Subobjects
Data Type	Unsigned 8
Access modes	RO
PDO Mapping	NO
Value Range	-
Default Value	4

<b>Index</b>	<b>Sub index 1 to Nr of input lines</b>
Name	Sub Unit Config Register 2
Description	This object is directly exchanged with the KONTURflex-Register 0x2018 Word 2
Data Type	Unsigned 16
Access modes	RW
PDO Mapping	No
Value Range	1 .. 255
Default Value	1

### 9.20 Index 421B : Sub Unit Config Register 3

This object sets the tolerance for detection of the middle of the track.

<b>Index</b>	<b>421Bh</b>
Name	Sub Unit Config Register 3
Description	-
Data Type	Array

<b>Index</b>	<b>Sub index 0</b>
Name	Max number of light grids
Description	Nr of Subobjects
Data Type	Unsigned 8
Access modes	RO
PDO Mapping	NO
Value Range	-
Default Value	4

<b>Index</b>	<b>Sub index 1 to Nr of input lines</b>
Name	Sub Unit Config Register 3
Description	This object is directly exchanged with the KONTURflex-Register 0x2018 Word 3
Data Type	Unsigned 16
Access modes	RW
PDO Mapping	No
Value Range	1 .. 255
Default Value	2

### 9.21 Index 422C : Sub Unit State

This object shows the state of the light grid modules of the KONTURflex system.

Index	422Ch
Name	Sub Unit State
Description	-
Data Type	Array

Index	Sub index 0
Name	Max number of light grids
Description	Nr of Subobjects
Data Type	Unsigned 8
Access modes	RO
PDO Mapping	NO
Value Range	-
Default Value	4

Index	422Ch
Name	Sub Unit State
Description	Bit0 no beam detects object Bit1 all beams detect object Bit2 object path in the middle Bit3 object path too high Bit4 object path too low Bit5 hole detected Bit6 reserved Bit7 light grid connected This object is directly read from the KONTURflex-Register 0x202C
Data Type	Unsigned 8
Access modes	RO
PDO Mapping	YES
Value Range	-
Default Value	

For applications, that require detection of failing of single light grid modules, it is recommended to map these objects to a PDO.

## 9.22 Index 4234,5,6,7 : Sub Unit Measuring Field

This object configures the measuring field for the light grid modules of the KONTURflex system. The measuring field enables blanking of single beams within the light grid modules.

For each light grid there is an own measuring field object.

Object	Connected light grid
4234	Light grid module 1
4235	Light grid module 2
4236	Light grid module 3
4237	Light grid module 4

Index	4234, 4235, 4236, 4237h
Name	Sub Unit Measuring Field
Description	-
Data Type	Array

Index	Sub index 0
Name	Max number of beams
Description	Nr of Subobjects
Data Type	Unsigned 8
Access modes	RO
PDO Mapping	NO
Value Range	-
Default Value	40h

Index	4234, 4235, 4236, 4237h
Name	Sub Unit Measuring Field
Description	This object is directly exchanged with the KONTURflex-Register 0x2034
Data Type	Unsigned 8
Access modes	RW
PDO Mapping	NO
Value Range	-
Default Value	

## 10 Emergency Messages

The KONTURflex CANopen supports several emergency messages. For all emergencies the same structure is used:

Byte							
0	1	2	3	4	5	6	7
EMY-Code		100 1	0	CO4xxx-Code			

EMY-Code: Emergency-Error-Code according to DS301

1001: Content of Object 1001

CO4xxx-Code: Emergency-Error-Code for CO4xxx as unsigned 32 value

CO4xxx-Code (hex)	May change		Description
	NMT	I/O	
8000 0000	X	X	CAN bus is bus off
4000 0000			CAN bus in error warning state
2000 0000			Node guarding warning
3000 0000	X	X	Life guarding error
0000 0002	X	X	Host Communication Time-Out
0000 0004	X	X	Host Communication Data Error

Emergency 2000 0000 (Node guarding warning) must be enabled with object 2103.

If more than one error is active at the same time, the bitmap of the CO4xxx-Codes for all active errors are combined with a logical or conjunction.

Some of the emergencies may cause a NMT state change and/or may force the output pins to the error state. This behaviour depends on the setting of object 1029.

The ID for emergency transmission is fixed to:  
0x80 + \$NodeID.

**List of emergency messages:**

<b>Node-Guarding Warning</b>							
30	81	01	00	00	00	00	20

This warning occurs, if the masters fails to transmit the guarding remote frame within the specified Guard Time object 100C and if transmission is enabled in object 2103

<b>Life-Guarding Error</b>							
30	81	01	00	00	00	00	30

This error occurs, if the masters fails to transmit the guarding remote frame within the specified Life Time (Guard Time object 100C multiplied with Life Time Factor object 100D)

<b>Host Communication Time-Out</b>							
10	23	01	00	02	00	00	00

This error occurs, if the communication with the KONTURflex host controller is lost.

<b>Host Communication Data Error</b>							
10	23	01	00	04	00	00	00

This error occurs, if the communication with the KONTURflex detects illegal data.

<b>CAN Bus in Error Warning state</b>							
00	81	01	00	00	00	00	40

This error occurs, if the chips internal CAN module is in error warning state.

<b>Return from CAN Bus OFF</b>							
40	81	01	00	00	00	00	80

This message indicates a return from Bus OFF state.