



DB 112

Double Sheet Testing Unit



18 - 30 V  
DC

- Reliable detection of multi-layer paper sheets, plastic and metal foils as well as cards (e.g. telephone cards)
- Not affected by printing or metallic coating
- Measurement range from 20g/m<sup>2</sup> paper to 1200g/m<sup>2</sup> cardboard (300g/m<sup>2</sup> paper for VDB 112/2.3)
- Ultrasonic sensor in the M12 round-sleeve housing
- Plug connection
- Short-circuit proof transistor outputs
- Operating state indicated by means of LEDs
- Very small construction (can thus be used in applications with limited available space)
- No calibration required for VDB 112/2.3 because of fixed threshold

Dimensioned drawing

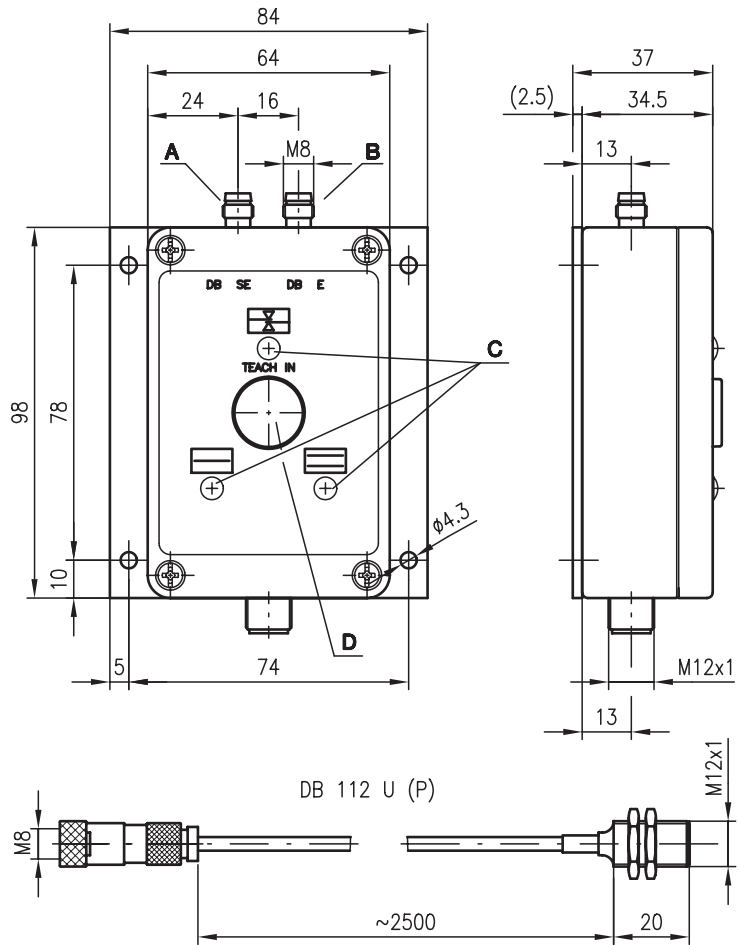

- A** Transmitter DB 112 U (P)
- B** Receiver DB 112 U (P)
- C** Indicator diodes
- D** Push button "TEACH IN"

Internal: parameterisation switch

Electrical connection

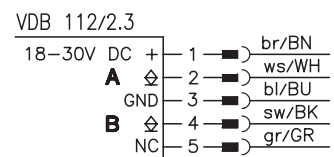
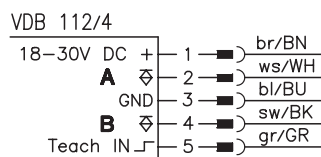

- A** Single sheet
- B** Double sheet

We reserve the right to make changes • db\_112\_e.fm



Accessories:

(available separately)

- M12 connectors (KD ...)
- Ready-made cables (KB ...) 5-pin: KB-095-5000-5A



## Specifications

### Sensor data

Operating range  
Converter frequency  
Sound cone

### DB 112 UP

10 ... 30 mm  
300 kHz  $\pm$  2%  
approx. 12°

### VDB 112/4

### Timing

Switching frequency  
Input pulse

200 Hz  
min. 5 ms  
min. 4 ms (VDB 112/2.3)  
 $\leq$  100 ms

Delay before start-up

$\leq$  100 ms

### Electrical data

Operating voltage  $U_B$

18 ... 30 VDC  
(incl. residual ripple)  
10 ... 30 VDC (VDB 112/2.3)  
 $\leq$  15% of  $U_B$

Residual ripple  
Bias current  
Switching output  
Function

$\leq$  75 mA  
2 transistor outputs  
single sheet detected or  $\geq$  1 sheet detected  
double sheet detected or  $\geq$  2 sheets detected  
 $\geq (U_B - 2V) / \leq 2V$   
max. 200 mA per output  
 $R_{in} = 10 k\Omega$   
 $\geq 6V / \leq 2V$  or not connected

Signal voltage high/low  
Output current  
Teach input  
Teach-in, active/not active

### Indicators

LED green **A**  
LED green flashing **A** (VDB 112/4)  
LED yellow **B**  
LED red **C**

double sheet testing unit ready  
teach-in event  
single sheet detected  
double sheet detected

### Mechanical data

Housing  
Weight  
Connection type

nickel-faced brass  
20 g  
M8 connector, 3-pin, with  
2.5 m cable

aluminium, powder coated black  
400 g  
M12 connector, 5-pin

### Environmental data

Ambient temperature  
(operation/storage)  
Protective circuit <sup>1)</sup>  
VDE safety class  
Protection class  
Electromagnetic compatibility

0°C ... +60°C / -40°C ... +70°C

1,2,3  
III  
IP 65  
severity level 3 acc. to  
(IEC 801-4 and IEC 17 B  
(CO) 180-I and II)

1) 1=transient protection, 2=polarity reversal protection, 3=short circuit protection

## Tables

## Diagrams

## Order guide

	Designation	Part No.
Sensor pair	DB 112 UP	500 38342
Amplifier (PNP switching outputs)	VDB 112/4	500 38343
Amplifier (NPN switching output, no TEACH required)	VDB 112/2.3	500 41129

## Note



## DB 112

### Technical description

#### General

The Ultrasonic Double Sheet Testing system consists of an analysis amplifier VDB 112... and an ultrasonic sensor pair DB 112 UP. It checks primarily paper, plastic and metal foils which are guided in by feeders. Each sheet is compared with a reference value stored in memory and, in the case of a double sheet, indicated appropriately.

#### Mounting

Transmitter and receiver (DB 112 UP) are constructed identically and must be mounted at an angle. This angle depends on the sheet material used and is specified in the table in the section "Installation and remarks". A larger angle of inclination increases the flutter range. E.g., at a 40° pitch, fluttering within 60% of the measurement field is allowed. The minimum distance between the transmitter and receiver is 10mm and the maximum distance is 30mm.

Exact alignment ( $\pm 1^\circ$ ) must be ensured. Alignment which is not in line with the axis results in a reduction of the working range.

#### Function

Referencing possibilities (calibrate or Teach)

- To achieve a secure detection of double sheets for all materials to be processed, it is recommended to always use the single medium as a reference. Switch S1 in position "1" (Teach).
- In the case of inhomogenous materials, e.g., materials with trapped air or high bulk paper, the referencing can fluctuate significantly depending on the scanning location during the calibration. These materials can be checked using a constant reference value (Ref. constant). "S1"-switch in "0"-position (Ref. constant)

The analysis unit can be operated in two different referencing modes.

- **a) Switch S2 in position "1" (man.)**

A calibration with the material to be detected can be performed either by pressing the "TEACH IN" button on the top of the device or by means of a control command sent to the "TEACH IN" input. The reference value remains stored until the next calibration process.

- **b) Switch S2 in position "0" (Auto)**

Calibration as described under "a)", as well as automatic "TEACH IN" during sheet intake and when applying the supply voltage if a sheet is located between the sensors at this time. An automatic calibration process is performed during sheet entry if no sheet is present in the measurement field for  $\geq 2$ s.

#### Function characteristics VDB 112/2.3

No teach-in is required after a change in material due to a fixed reference value in the device. It is possible to check the alignment quality of the transmitter and receiver with a voltmeter ( $R_{in} 1 M \Omega$ ) at the test point. A paper sheet of approx. 300g should, when inserted, result in a measurement value of approx. 4VDC.

#### Operation

The evaluation unit VDB 112/... continuously indicates the situation between the sensors via two outputs.

The output "Single sheet detected" is activated as long as one or more sheets are located in the measurement field.

The output "Double sheet detected" is activated as long as two or more sheets are located in the measurement field.

The reference value remains stored even after a voltage interruption.

## Controls and indicators

- A LED green
- B LED yellow
- C LED red
- D Testpoint 0 ... 4VDC
- E GND
- S1 Switch: Teach/Ref. constant
- S2 Switch: Teach man./auto

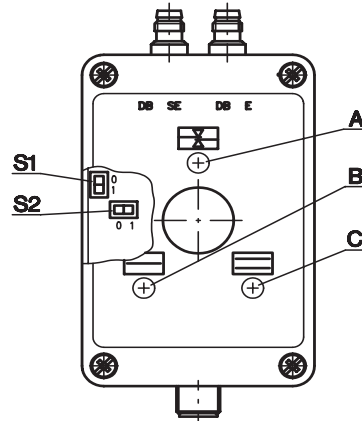
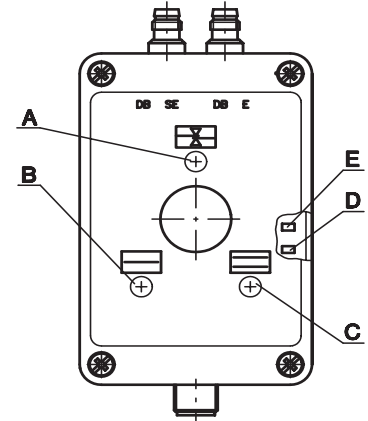
**VDB 112/4**

**VDB 112/2.3**

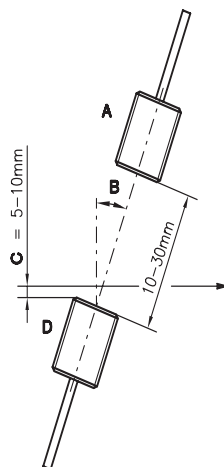
## Mounting and notes



- A Receiver
- B Angle of inclination
- C Sheet material
- D Transmitter

### Note

- When aligning transmitter and receiver, care must be taken to align them as exactly as possible. To achieve proper functionality, the sensors must be tilted towards the normal by an angle "B".

Sheet material	Recomm. angle of inclination B		
	0°	15° ... 25°	25° ... 35°
Standard paper up to 150g/m <sup>2</sup>	X	X	X
Cardboard		X	X
Plastics			X